

# OILING AND INSTRUCTION CHART

for

## CHANDLER & PRICE NEW SERIES PRESSES

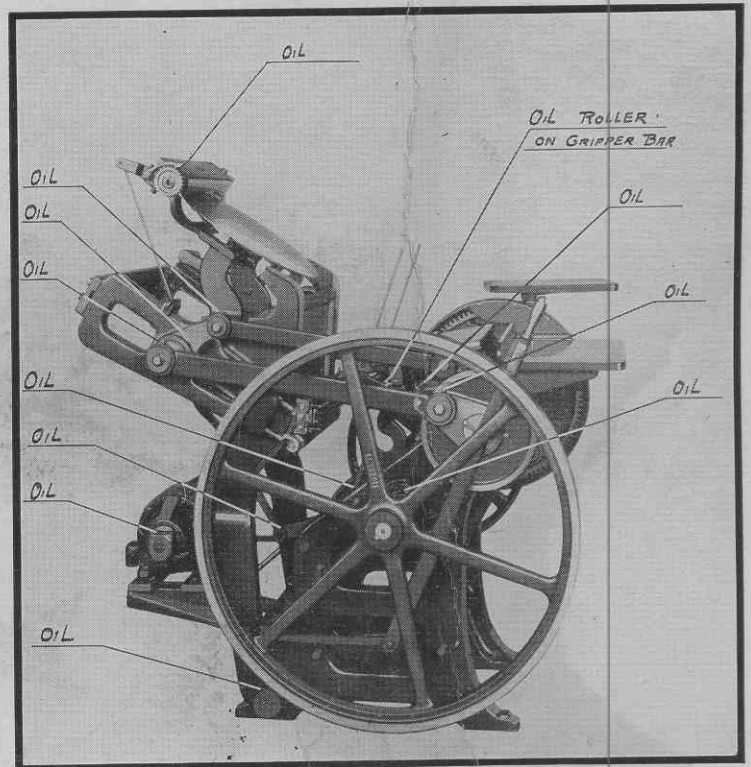
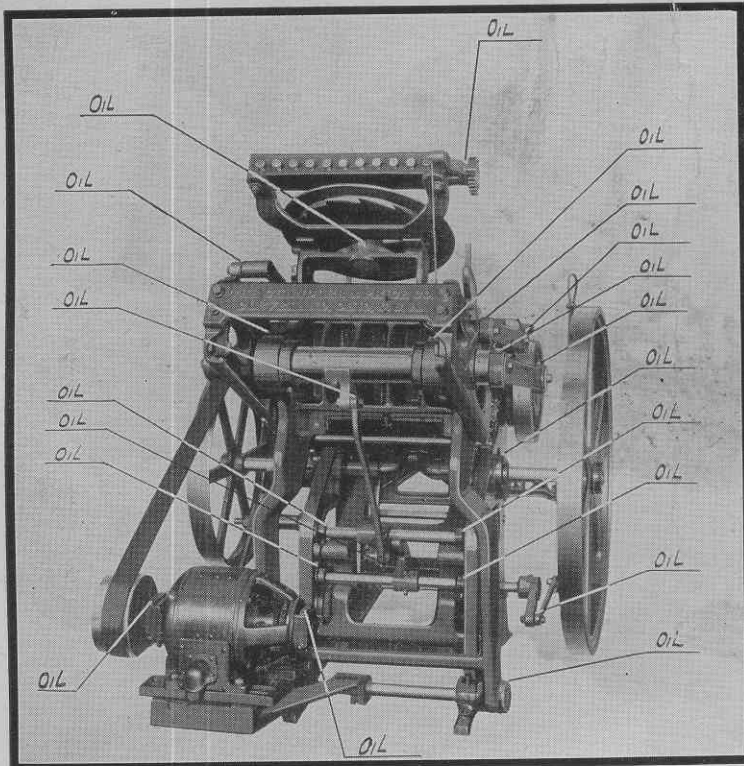
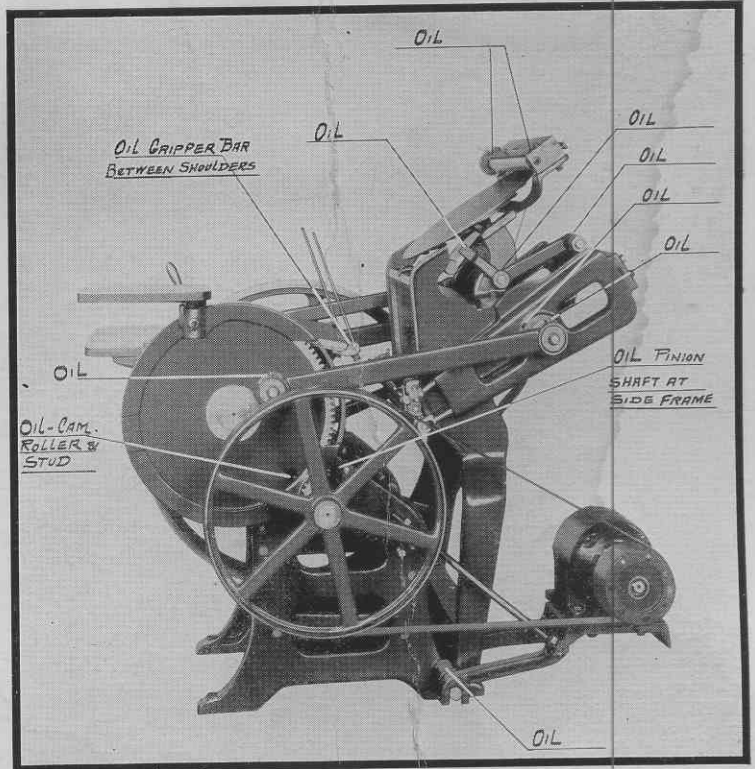
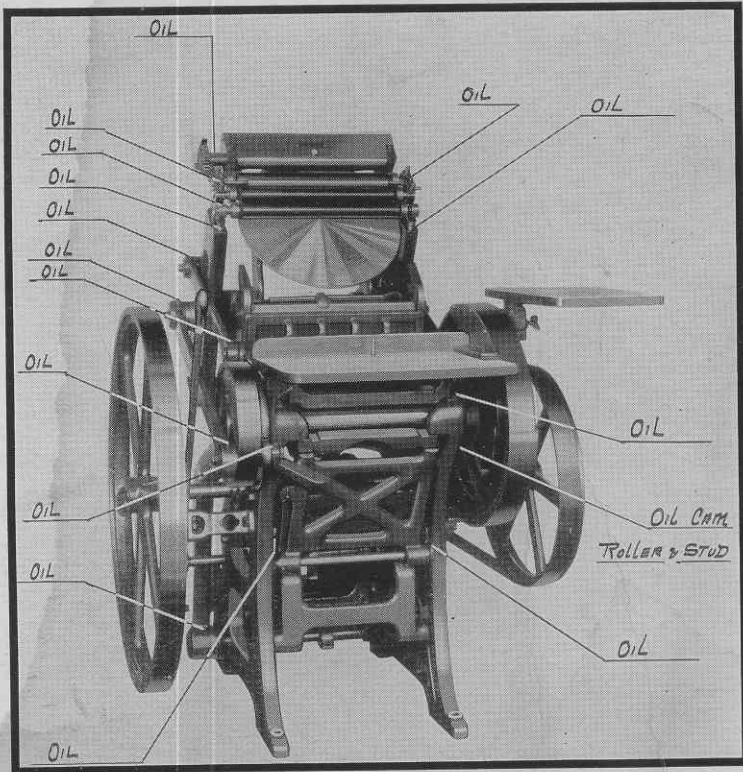

# C&P News Series Oiling Chart Front of Press

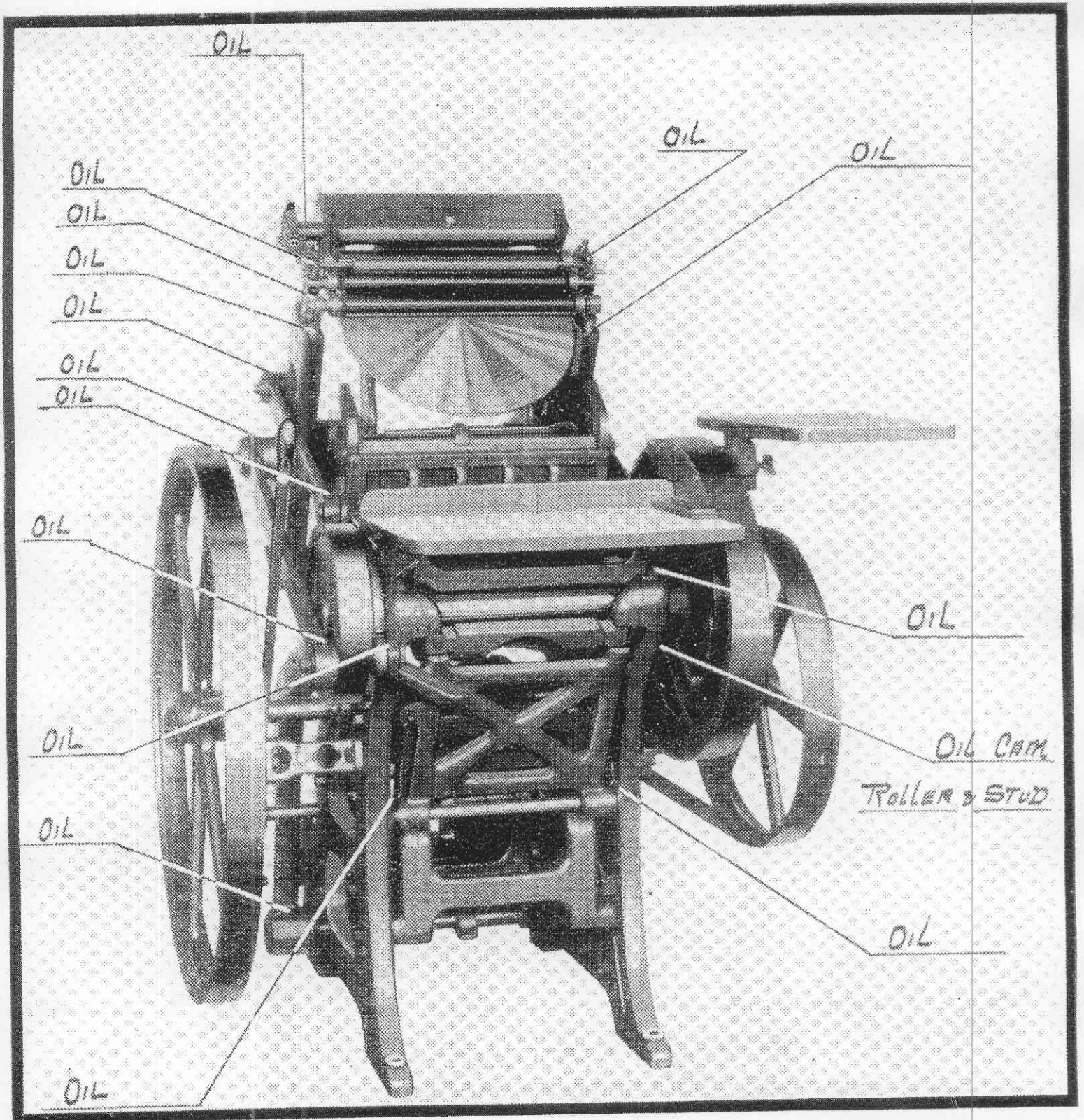

# C&P News Series Oiling Chart Back of Press

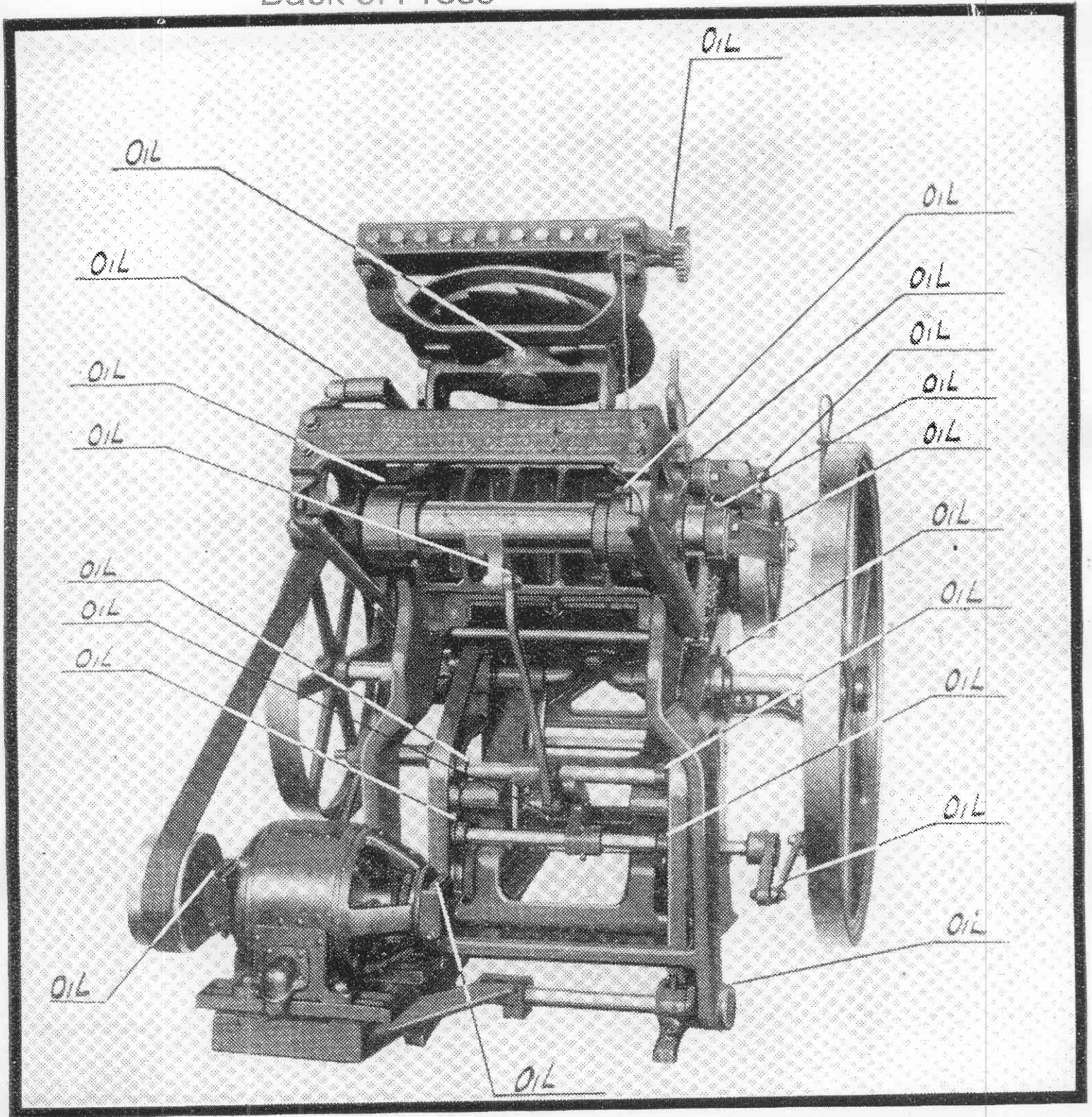



# C&P News Series Oiling Chart Left Side of Press

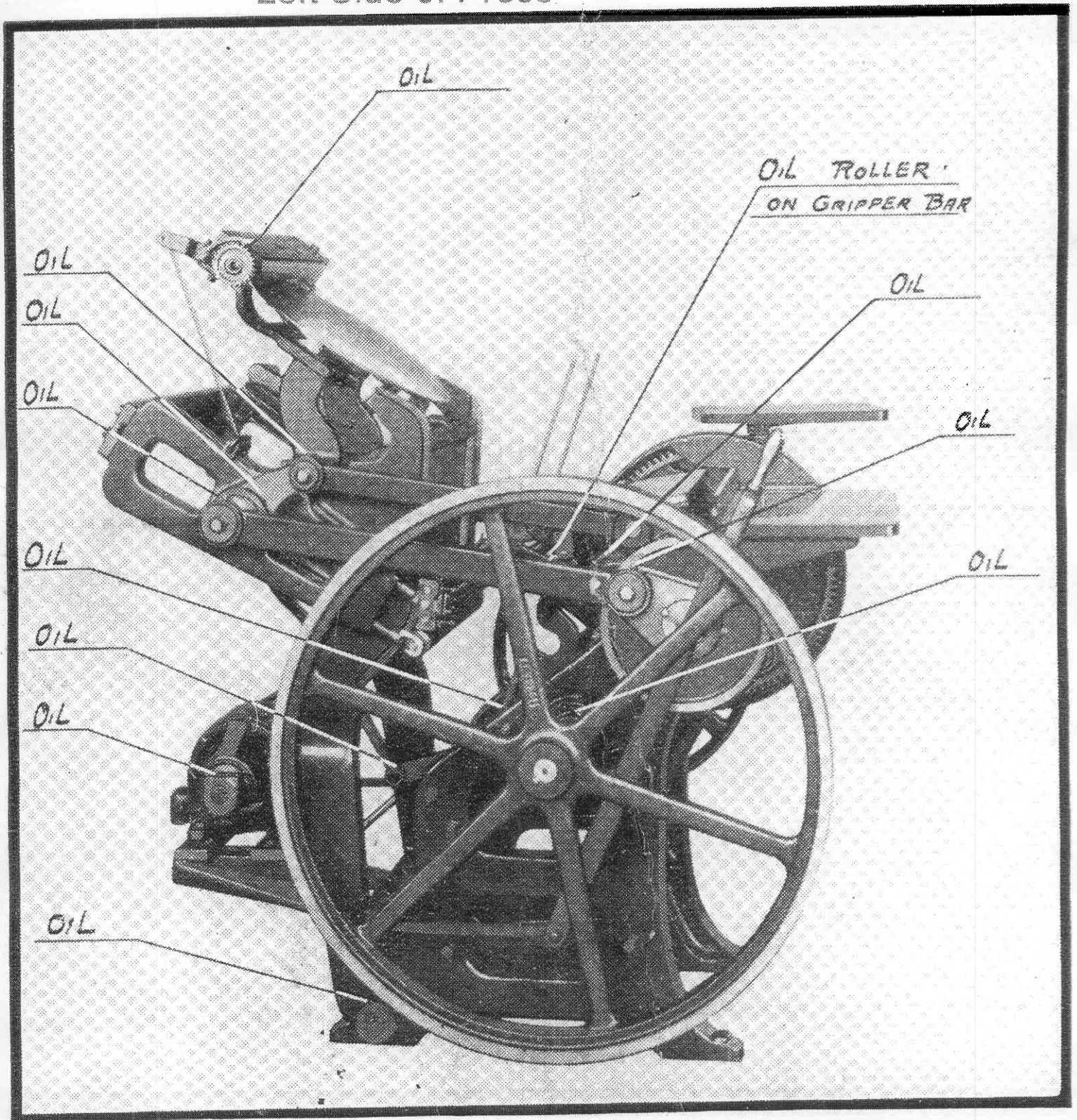

# INSTRUCTIONS

**S**EE that the press is upon a firm foundation and that it stands on all four feet. Level it up with a spirit level, using this upon the main shaft in front and the back shaft at the rear.

Before running the press wipe off all dirt and grease, and make certain that the oil holes are not stopped up. Next, oil the press carefully, using a good grade of machine oil.

There are about thirty-seven oil holes; in addition, all joints of the throw-off, the rocker lock and the cam roller and stud in the raceway of the large gear cam wheel should be oiled.

The side arms, roller saddles and roller stocks require special attention. Oil these parts frequently, especially when the press is new. Have the press wide open when the saddle bearings are oiled.

It is a good plan when oiling the press to always start at a certain place, go all over the machine and end up where you started. Run the top of the flywheel from you.

**THE CHANDLER & PRICE COMPANY**

*Cleveland, Ohio, U. S. A.*

(OVER)