

**MODEL K Elrod**

---

**MANUAL OF INSTRUCTIONS AND PARTS LIST**

MODEL **K** ELROD

District Sales Offices:

NEW YORK (17) 589 Fifth Avenue

BOSTON (10) 470 Atlantic Avenue

ATLANTA (3) 120 Marietta Street

SAN FRANCISCO (3) 5 Third Street

**instructions**  
**maintenance**  
**parts list**

LUDLOW TYPOGRAPH COMPANY

2032 Clybourn Avenue, Chicago 14, Illinois

•

Cable Address:

LUDTYPE, CHICAGO

### How to Order Parts

1. Look up part wanted on Plates 1 to 10 of the Parts Manual in order to obtain part number. Description of part is given on following page or pages.
2. When ordering parts, give part number and name, and serial number of machine.
3. When ordering electrical parts, give the voltage, and state whether current is alternating or direct. Also give cycles of alternating current.
4. Please specify whether shipments are to be forwarded by first-class mail, air mail, parcel post, express or freight.

Place your machine Serial Number  
here, for convenience in ordering parts:

Serial No. \_\_\_\_\_

# Installation of the Model K Elrod

---

The minimum space requirements for the Elrod are as follows: Total space required, 6 feet by 9 feet. In this space the Elrod should be placed the long way to leave a space of at least 18 inches between the back of machine and any obstruction, to provide for cleaning and oiling. A space of at least 2 feet should be allowed at the left end in order to provide room for manual operation of plunger and adjusting of pressure oiler. Also allow a space of 1 foot at the right end for working room. The operator works in front of the machine and requires a minimum of 2½ feet of space. If possible, more room in which to work is desirable.

## Electrical Connections

For electric-heated machines, the power wires are connected to the rear of fuse and switch panel. Use No. 8 gauge wire for 110 volts, and No. 10 gauge wire for 220 volts. For gas-heated machines, a No. 14 gauge wire is required for the motor.

## Gas Connections

A ½ inch pipe is used for gas-heated machines, and this should be connected to a supply line of sufficient capacity to prevent pressure fluctuation, particularly if other machines are connected to the line.

## Water and Drain Connections

Connections for both inlet and outlet are made at the rear of the machine. A shut-off should be provided on the main water supply pipe line. This water supply line should be ½ inch pipe, which is reduced to ⅜ inch at the machine. The drain pipe should be ¼ inch pipe or larger.

The Elrod is shipped assembled, except for the following parts: Motor pulley, metal drip cup, mold cover, molds, pressure oiler weight, water drain sight glass and starting strips. Accessories are separate. In the case of some export shipments the motor is separate.

**CAUTION:** When uncrating and moving the machine into posi-

tion, it is very important that the material table NOT be used to lift the Elrod, as this may damage the gauge rod.

The Elrod should be placed on a sheet metal plate, preferably on Elrod Base Tray EC1000, which is furnished as an accessory. This base tray has reinforced edges to keep it flat and to hold oil drippings so they do not spread on the floor and create a slipping hazard.

In placing the Elrod in position, take care to see that there is no twist in the frame as it rests on the floor. The right end of the machine should be lifted about ⅛ inch off the floor by means of a jack or a block, and a wedge placed under the center of the cross member of the right leg. Place a piece of paper under each foot of the right leg, and then lower the machine until one of the papers is lightly gripped by one foot. Then place shims of leads or slugs under the opposite foot. Do not force this shimming material into place. Then remove the jack or block and wedge.

## Motor

Except in the case of some export shipments, the motor is mounted in place with the motor lead wires connected. The motor pulley should be placed on the motor shaft, with the smaller diameter of the pulley toward the motor. The set screw in the pulley should bear against the flat surface of the motor shaft, and be firmly tightened.

Where the motor is shipped separately, it should be fastened to the motor table with the four screws provided, the pulley side of the motor being away from the crucible end of the machine. The screw connections on the lead wires should be taped with rubber and friction tape.

## Direction of Rotation

The motor armature must rotate in a clockwise direction when facing the motor pulley.

## Speed

When the belt runs from the small pulley on the motor to the large

pulley on the counter shaft, a speed of approximately 56 strokes per minute will be obtained. When the belt runs from the large pulley on the motor to the small pulley on the counter shaft, a speed of approximately 84 strokes per minute will be obtained.

#### **Metal Drip Cup**

The metal drip cup should be kept on the top of the main table, under the mold housing, to catch metal drippings.

#### **Mold Cover**

The mold cover drops over the outer end of the mold chamber and should always be in place when material is being produced, for protection in case the strip breaks. This mold cover supports a sliding plate that is held in place by the material as it passes through the machine. When the material breaks inside of the mold, this plate automatically slips down by gravity and prevents the molten metal from splashing out. If the strip of material breaks outside of this cover, no metal will splash out.

#### **Molds**

Each mold bears a serial and a style number. The intake end of the mold has a short slot, a round hole, or several holes. The opposite end has a long, beveled slot and this opening corresponds to the shape of the material to be produced.

The intake end of the mold should be inserted in the mold chamber, with the heads of the screws on the side of the mold facing the front of the machine. The mold protrudes about  $\frac{3}{4}$  inch when placed in position.

The molds should be kept in the mold container, and Elrod mold oil should be poured in until it just covers the mold baskets.

#### **Pressure Oiler Weight**

This is placed in position as shown in illustration on Plate 7. The pressure oiler comes filled with oil. See that sufficient Elrod mold oil is in oil cup.

#### **Water Drain Sight Glass**

This is placed in position over the water drain cup.

#### **Starting Strips**

Starting strips are furnished with each machine. These strips are *not* samples, but are required for the starting operation. When the machine is in operation it is important to set aside several full length strips for use as starting strips before the machine is shut down.

#### **Testing**

After the machine is set up and all electric, gas and water connections are made, remove the Plunger Pin 1318B, Plate 4. Turn the machine over by hand a few times, and if everything seems to be functioning properly, turn on the motor switch and allow the machine to run a few minutes.

Observe the action of the machine and the function of each part. See that all bearings and moving parts are thoroughly lubricated. For bearing lubrication use a good grade of machine oil. S.A.E. 20 is a good viscosity to use. The main shaft bearings are lubricated by four pressure grease fittings located in back of right-hand side of front panel. A pressure grease gun is supplied as standard equipment, and a good grade of high temperature grease should be used. It is recommended that the main shaft bearings be lubricated weekly. *Never use Elrod mold oil for bearing lubrication.*

If the machine operates smoothly and without effort, turn off the motor switch and replace the plunger pin.

#### **Heating Crucible**

As the machine is shipped, there is just enough metal in the electric crucible to cover and protect the crucible heaters. No type metal is included in the gas crucible. If possible, molten type metal should be put in the gas crucible before lighting the gas burners.

Before turning on the heat be sure the machine is in the regular idle position, with the plunger at the bottom of its travel. This position will bring the zero marks on the hand wheel and on the left end of the table in alignment. The Sealing Valve EC1396D should be in the closed position—which means turning it to the right, or clockwise—in order to prevent the metal from flowing out through the mold housing after it becomes molten.

On the electric-heated machine, turn on the crucible heater by closing the switch on the control panel.

On the gas-heated machine, light the "crucible burner."

The metal level in the crucible should be about  $\frac{3}{4}$  of an inch from the top. It takes about 1 hour and 20 minutes to melt a full crucible of type metal on the electric-heated machine, and 1 hour and 30 minutes on the gas-heated machine.

The thermostat on the electric-heated machine is adjusted when it leaves the factory, and should automatically maintain the temperature of the metal in the crucible between 590° and 600° Fahrenheit when heated and the machine is idle. Use a thermometer to check the operation of the thermostat when machine is installed. If the thermostat is out of adjustment it may be readjusted by removing Dial 3315-1, Plate 3, and loosening the holding screws and changing the adjustment to either raise or lower the setting to correspond to the hot metal thermometer reading.

#### **The Gas-Heated Elrod**

The gas crucible, which is shown on Plate 4, has a crucible burner, a throat burner and a mold housing burner. The arrangement of the gas supply and heating system is shown in its entirety on Plate 5. The crucible burner is automatically controlled by a thermostat, which maintains the temperature between 585° and 600° Fahrenheit.

The gas thermostat is adjusted at the factory, but may have to be readjusted for local gas conditions by turning the Gas Governor Adjusting Screw EC1816, Plate 5, as desired, using a thermometer to check the thermostat.

The throat burner is used to maintain the temperature of the metal in its passage from the crucible through the throat to the mold. All variation in heat is by manual control of the throat burner.

The mold housing burner is used for sealing and unsealing the mold, and should not be used when material is being produced. *To avoid overheating the mold and consequently damaging it, the operator should never leave the machine during the sealing or unsealing operation.*

The spud in each of the burners calibrates the quantity of gas. Two

extra spuds are furnished for each burner, so exact control of gas can be made. The air mixer sleeve on the burners controls the amount of air. The proper mixture of air and gas is one that will burn clean without "popping," and that will direct the hottest portion of the flame to the surface to be heated. A piece of  $\frac{1}{16}$  inch iron wire placed in the path of the flame will disclose the hot and dead portions of the gas flame.

Aside from the fact that perhaps a little closer attention must be given to the proper regulation of heating and cooling conditions which the nature of gas fuel makes necessary, the operation of gas-heated and electric-heated machines is very similar, and instructions for the operation of the electric-heated machine will apply to the gas-heated machine.

### **How to Start the Elrod**

#### **1—Prepare Mold**

The Mold Container AEC1020A is mounted on the rear of machine. Elrod Mold Oil AEC1250A is poured in the container until it just covers the Mold Baskets AEC1022 and AEC1023. The molds should be placed in these mold baskets when not in use. To prepare a mold for use, remove it from its mold basket and set it upright, small end down on top of the remaining molds. It will be drained and ready for use if this is done as the first operation in starting the Elrod.

(Additional information on molds is contained in the section on "Maintenance.")

#### **2—Turn on Heaters**

When the type metal in the crucible is cold, the crucible heater should be turned on 1 hour and 30 minutes before starting the Elrod.

On the electric-heated Elrod, the switch on Panel A3350, Plate 3, should be turned on and the crucible heater switch should be turned to "On" position. This switch is a combination thermostat-and-heater "On" and "Off" switch. After the switch has been turned to "On" position, the thermostat-switch is actuated by a mercury bulb in the crucible, and a capillary tube from the crucible to the thermostat switch. Set the thermostat knob to 600° Fahrenheit. The lighted small

neon "glow lamp" indicates that the heater is "on." When the switch is in the "On" position and the lamp is not lighted, the crucible temperature has reached the point indicated on the thermostat knob, and the crucible heater is "off." On the gas-heated Elrod, the "crucible burner" is turned on.

When the type metal in the crucible is molten, turn on the "throat" and "sealing" switches on the front of the electric-heated Elrod. The throat heaters are also controlled by a thermostat-switch, and the throat temperature is regulated by a separate mercury bulb in the bottom of the mold housing, with a capillary tube to the throat thermostat-switch.

The temperature setting of the throat switch is governed by the size of material to be cast, and may vary approximately 15° F plus or minus from the following recommended temperatures:

<i>Size of material to be cast</i>	<i>Temperature</i>
1-pt. to 6-pt. inclusive	625° F
above 6-pt.	575° F

This setting of the throat thermostat-switch depends to some extent upon the line voltage, the temperature of the water which cools the mold housing, the temperature of the metal in the crucible, and the quality of the metal being used.

The sealing heaters SHOULD NOT be turned on until the crucible is melted out and machine is ready to be used for the production of material, as the cartridge sealing units are high-heat, fast-acting heaters requiring a minimum of time before bringing the mold chamber to proper temperature for operation (average five minutes).

On the gas-heated Elrod, light the "throat burner" and the "mold housing burner."

**IMPORTANT:** Because of the high temperature that can be generated in the mold housing and the possibility of damaging the molds by overheating, never leave the machine during the sealing or un-sealing operation.

If the metal is cold and the machine is not set at zero, it would mean that the mold was carelessly left in when the motor was turned off.

In this case turn on the heat in the crucible only, and as soon as the type metal is melted, set the machine to the zero position and see that the sealing valve is closed before turning on any other heaters. If this is not done, the metal will flow out of the crucible.

The metal level in the crucible should be kept to about  $\frac{3}{4}$  of an inch from the top. A metal feeder is desirable in order to maintain proper metal level, even temperature, uniform product and saving of operator's time.

The temperature of metal in the crucible is maintained between 590° and 600° Fahrenheit by the thermostat.

### **3—Check Operating Adjustments**

The following parts are supplied to be used with the various size materials to be produced:

#### **Puller Wedge Plates**

There are four puller wedge plates marked for various point sizes. For the 18-pt. size the puller wedge is used without a plate.

#### **Release Plates**

There are two release plates. The one with long extensions is used up to and including 4-pt. For sizes above 4-pt., use release plate without extensions.

The same Knives and the same Material Holding Catch are used for all sizes of material.

The Cutter Head Guide Plate is adjusted by loosening the knurled knob and moving the plate forward or backward to the thickness of material to be produced. The setting is by "eye."

Material Guide Plate 3604, Plate II, is located at the rear of the material table and is adjusted by means of the two knurled wheels located at the rear of the guide plate. The material table is marked in point sizes from 2 to 18-pt. just in front of the guide plate. Adjust each end of the guide plate to the point size of the material to be run.

#### **Puller Mechanism**

The length of stroke is regulated by a screw-and-nut arrangement located to the left and the rear of the puller mechanism. When starting

the machine, the screw is adjusted so that it just touches the wedge. In this position the wedge is inoperative and no "pull" results. To increase the length of "pull" or stroke, the knurled nut is turned so that the screw moves toward the left. The opening between the end of the screw and the wedge indicates the length of stroke, which should be adjusted to the required stroke for the various thicknesses of material. This can vary from three to seven picas, depending upon size of material and operating conditions.

#### **Motor Pulley**

High speed (84 strokes per minute) may be used for all sizes (rule or base material) except 12-pt. and 18-pt., for which low speed (54 strokes per minute) is recommended.

#### **Plunger Pressure**

This adjustment is set at the factory and need not be changed for various size materials. However, when casting from 12-pt. and 18-pt. molds, it is important that the plunger gag be used for at least the first two or three strips.

#### **4—Prepare Starting Strip**

*All starting strips must be shaved undersize* so they will enter the mold easily, thereby avoiding any possibility of damage to the inner surface of the mold.

The strip of material is laid on a flat surface and an Elrod Material Scraper is pulled over it three or four times, removing a slight amount of material on the two sides, and the top and bottom, for a distance of about 4 inches from the end.

For 18-pt. cored molds, proceed as follows: Using the proper reamer, ream the core holes for a distance of at least two inches and scrape off about one-half point of material from each of the four sides of the material for a distance of about four inches from the reamed end.

When properly prepared, the starting strip should slide easily into the mold for about two inches. If it doesn't, this strip has been improperly prepared. *Never force the starting strip into the mold.* Cored molds are particularly easy to damage if force is used.

#### **When Starting Strip is Not Available**

Use two or more smaller size strips that will total the point size of mold. Shave the outsides of the combined strips.

For 12-pt. hollow slug mold, use a 2-pt. lead and 6-pt. slug for the center and a 2-pt. lead for each side. Scrape the side leads and push them into the mold. Push the two middle strips against end of core. After the mold is heated, keep shoving the two outside strips into the mold as you open the sealing valve, meanwhile being sure that the center strips are kept firmly pressed against the core.

#### **5—Clean Mold Housing, Insert Mold**

When metal in cooling indicator is molten, clean out the mold housing with Mold Housing Scraper AEC1715B.

Take the mold which has been draining, wipe off excess oil and insert in mold housing, with the intake end pushed lightly against the diffusion tube, and the heads of the screws facing the front of machine. If it does not slide in freely, use the mold housing scraper again.

Puller wedge shims and release plates for sizes below 6-pt. are made longer than for sizes 6-pt. and larger. The mold cannot be inserted when these parts are in place, so they must be inserted after the mold is in place, and must be taken out before the mold is removed.

#### **6—Insert Starting Strip**

Place the prepared starting strip in position, with the puller wedge out. When this is done, the strip can be pushed through the puller mechanism. *Never drive the starting strip, as this will always damage the mold.* If starting strip does not go in easily, remove it and scrape it some more.

Lay a 2-pt. strip on the material table and let the right-hand end of the starting strip rest on it when sealing the mold. This helps to keep the mold parallel during the sealing operation.

Then place the sealing plate over the end of the mold, pressing it against the mold housing.

#### **7—Open Sealing Valve, Seal Mold**

At this point the metal in the cooling indicator should be entirely melted.



Wait until the mold is hot enough so that the starting strip which is held gently against the mold begins to melt. When this point is reached the starting strip will slide in freely.

Then, while pressing the strip slowly and constantly into the mold, open Sealing Valve EC1396D, Plate 1, by turning it counter-clockwise, one-quarter of a turn.

After a few seconds the molten metal will start to flow around the top and sides of the mold and trickle into Metal Drip Cup AEC1337B. Then slowly turn Water Valve EC3227, Plate 1, to the "On" position. This will allow a stream of water to flow around the mold chamber and will stop the flow of metal by "freezing" it.

#### **8—Pump Air from Mold Chamber**

As soon as the metal is "frozen" around the front end of the mold, close the sealing valve and then pump air from the mold chamber by operating Plunger Lever Handle EC1315D, Plate 1, up and down once or twice by hand.

If this is not done, with the sealing valve closed, air trapped between the mold and the mold housing may prevent proper, solid sealing-in of the mold, which is so important, or trapped air inside the mold may prevent proper joining of the starting strip, which would necessitate starting over again.

When the water flows evenly in the water drain sight glass, reduce the flow so that the mold housing will not chill too quickly.

Adjust the water as indicated on chart on page 14. This chart is based on unusually cold water, so it may be necessary to use a slightly smaller stream of water. The matter of water regulation is very important, and after experience is gained as to the best regulation under the particular conditions in the plant, a special chart should be made up to fit these conditions. See "Correct Appearance of Strip" on page 00 for information on how to recognize the best operating condition. Now remove the sealing plate, and put Mold Cover AEC1328C in place. This covers the end of the mold, and has a sliding plate that rests on the strip.

*Note—Never leave the machine during sealing operation.*

#### **9—Adjust Heaters**

Turn off "sealing" switch on electric-heated machines, shut off "mold housing burner" on gas-heated machines.

Adjust throat heater dial to required temperature on electric-heated machines, and the throat burner on gas-heated machines. On gas-heated machines a higher operating temperature is required for smaller sizes of material as compared to the larger sizes. This adjustment is made by setting the throat heater dial.

The exact adjustment is obtained by observation of the cooling mark on the strip of material. When heat is too low, the cooling mark will be almost straight. When heat is correct, the cooling mark will be crescent-shaped. When heat is too high, the cooling mark will be arrow-shaped.

#### **10—Set Plunger Lever Lock**

Setting the lock is done by pressing down on the plunger lever handle with the left hand and turning Plunger Lever Lock 1316½, Plates 3 and 4, into position with the right hand. This holds the plunger in an inoperative position at the top of its stroke, and metal flows into the mold chamber by gravity through the port hole.

The use of the plunger lever lock is a safety measure on sizes 6-pt. and larger, because if too large a part of the metal in the indicator is molten, the congealing point of the strip is near the front of the mold, and if the plunger is operating when starting, it is possible that the down stroke of the plunger will push the strip out of the mold.

Do not use the plunger lever lock for sizes smaller than 6-pt. However, it is very important that the plunger lever lock be used when starting 12-pt. and 18-pt. material.

Insert puller wedge in position, making sure that the proper shims are installed and proper puller release plate has been placed in puller assembly.

#### **11—Turn on Motor**

Before turning on motor, recheck setting of belt speed, heat control, plunger gag (if material being cast is 6-pt. or above) and temperature of mold housing. The metal in the indicator on top of mold housing

shows the point in the housing at which the metal solidifies. The indicator should be "frozen" approximately  $\frac{1}{4}$  inch on right-hand end for 1-pt. and 2-pt. material,  $\frac{3}{4}$  inch for 6-pt. material, and 1 inch for larger sizes.

#### **12—Gradually Adjust Pull to Maximum**

After several revolutions of the machine, turn Knurled Knob 3423, Plate 9, on the stroke adjusting mechanism, and then gradually increase the pull of the puller wedge to the specified ems indicated on the chart on page 14. The smaller sizes of material can be brought up to the maximum pull faster than is possible with larger sizes of material.

Sometimes when starting, the first few strokes will carry too much oil, which frequently causes the puller wedge to slip. If it continues to slip, the puller wedge can be helped along by pressing its handle slightly to the rear of machine to add pressure against strip being cast at each stroke, until the oil disappears from the puller wedge and from the strip of material.

#### **13—Unlock Plunger Lock**

After running two or three strips of 6-pt. or larger material, unlock Plunger Lever Lock 1316 $\frac{1}{2}$ , Plate 1, by swinging it out of locked position while the machine is running.

#### **14—Adjust Pressure Oiler**

Allow the machine to operate long enough to use up the excess oil in the mold housing, and then turn on Pressure Oiler Shut-Off Valve EC1259, Plate 7. Set Pressure Adjusting Lever 1277B, Plate 7, so that the proper amount of oil appears on the strip.

Move the pressure adjusting lever to the left (as one faces the front of the machine) to decrease the pressure, and to the right to increase it. Larger materials, with greater shrinkage, require less oil than smaller materials with less shrinkage.

Too little oil or the absence of oil is indicated by the material having an excessively bright, dry appearance, particularly at the top of the sidewalls of the strip. This condition is very injurious to the mold, and the machine must not be operated without oil on the strip.

Excessive oil appears as a heavy, greasy film on the material, and the printing surface probably will have a ragged and irregular edge, or may be marked at intervals with a "break" or "pit" in the face.

Ideally-lubricated material shows a uniform gray sheen on the upper part of the sidewalls of the strip, the balance of the strip being smooth and bright, with a smooth, unbroken printing face.

With a little practice the operator will be able to gauge quickly and correctly the proper setting of the oiler to obtain ideally-lubricated material.

As the oil under pressure is consumed, the pressure-adjusting lever will be pulled downward by the weight until it reaches the bottom limit of its travel. Just before this takes place, close the shut-off valve, raise the lever to the top of its travel, and again open the shut-off valve. This recharges the oiler for several hours.

Be sure to fill the outer section of the oil reservoir at least twice a day when machine is in operation.

If the level of oil is allowed to fall below the port in the pressure cylinder, air will be drawn into the cylinder when the piston is raised for recharging. An air bubble will interfere with proper functioning of the oiler.

To remove air from the oiler, close the shut-off valve, put oil in the cup and pump the pressure-adjusting lever up and down, and continue putting oil in the cup until it remains full, after pumping. Then loosen the union at the top of the diffusion tube one turn and open the shut-off valve slowly so that the oil and bubbles of air will be forced out of the end of the oil feed line. As soon as the bubbles stop coming out, close the shut-off valve and tighten the union.

Then open the shut-off valve two or three turns so that a very small quantity of oil is forced out of the bottom of the oil diffusion tube. This will be visible in the form of smoke coming out of the mold chamber. Then close the shut-off valve, and the oiler is ready to operate.

It is exceedingly important that the right kind of oil be used. The use of any other than Elrod mold oil will result in poor material, damaged molds and unsatisfactory results. *The necessity of using this*

*particular oil cannot be stressed too much.* The Ludlow Typograph Company carries a supply for the convenience of its customers, packed in one and five-gallon cans.

### **How to Stop the Elrod**

Following are condensed instructions to be used as a guide for the sequence of operations. Complete instructions for performing each of these operations are on the following pages, and they have the same consecutive numbers as below:

15. Shut off motor after setting aside starting strips.
16. Turn hand wheel to zero position.
17. Open and close sealing valve.
18. Change heaters to maximum heat, and turn on sealing heaters.
19. Shut off water.
20. Shut off oil.
21. Wait for mold seal to melt out.
22. Remove and clean mold and put in oil.
23. Shut off heaters, except crucible heater.
24. Clean mold housing.
25. Pull plunger rod clevis pin A1319A.
26. Shut off motor.
27. Pull plunger lever all the way up by hand.

#### **15—Shut Off Motor**

Motor switch is located on left end of panel on front of machine.

Be sure that several full length starter strips have been laid aside before stopping the machine.

#### **16—Turn Hand Wheel to Zero Position**

Turn hand wheel located at left end of machine until zero mark on hand wheel is in alignment with zero mark on the left end of the table immediately above it.

#### **17—Open and Close Sealing Valve**

When the machine is stopped on zero position as previously instructed, the plunger is on the downward stroke and there is metal under pressure between the mold and the bottom of the plunger.

To relieve this pressure, open up Sealing Valve 3396, Plate 1, by turning it one-quarter turn counter-clockwise.

Then pull upward on Plunger Lever Handle A1315D, Plate 1, which will force Plunger 1327B, Plate 1, to the bottom of its travel and will relieve the pressure below it. If this is not done, a considerable quantity of metal will flow out of the mold chamber with removal of the mold.

Then close the sealing valve by turning it one-quarter turn clockwise, or toward the rear of the machine. If this is not done, the metal in the crucible will flow out when mold is unsealed.

Remove mold cover and leave the metal drip cup in place.

#### **18—Change Heaters to Maximum Heat**

On the electric-heated machine turn on sealing switch, and on the gas-heated machine turn on sealing heater and adjust throat burner to maximum.

#### **19—Shut Off Water**

Turn Water Control Valve 3227 counter-clockwise so that point is opposite the drain marking on the plate. This will remove all water from mold housing and speed up the melting-out process and prevent the formation of a scale deposit in the water jackets.

The operator must not leave the machine until the mold is removed and the heaters shut off.

#### **20—Shut Off Oil**

When the cooling indicator is entirely melted, the metal seal will also be melted and will run into the drip cup.

As mentioned before, do not leave the machine at this time.

#### **21—Remove and Clean Mold and Put it in Oil**

If the mold does not come out readily, do not try to force it, but wait a minute or so until it is hotter and the metal around the sides of the mold is more liquid. The mold can then be pulled out easily with the special pliers.

Holding the mold with the pliers, immerse it in the crucible with the large opening downward and hold it there until the chilled metal is melted. Pour some of the Elrod mold oil into the small opening and

dip the mold up and down a number of times in the metal. Then, with the large end downward, tap the mold gently on a block of wood to remove metal and dirt.

Hold the mold up to the light, look through the small end of the mold cavity to see if any metal or foreign substance adheres to the inner surfaces. If there is, reheat, oil, and tap on wood until the inside of the mold is absolutely clean.

Wipe off the outer surface of the mold with a clean rag and immerse the mold, while still hot, in mold container. This container should have sufficient Elrod mold oil in it to cover the baskets at all times.

If the mold should stick in the housing so it cannot be removed with the pliers, the special Mold Remover AEC1655A can be used. If this has to be done, there is an accumulation of dirt or dross in the mold housing that must be cleaned out.

The crucible throat behind the mold housing should be cleaned every three months to keep the METAL PASSAGE free from dirt and dross. Remove the diffusion tube and remove the dirt and dross with a long, flat metal tool. The small opening to the crucible well can be cleaned with a  $\frac{3}{8}$ " star drill. Be sure all loose carbon or dross is removed from mold chamber before resuming operation, and it is advisable to run one of the larger point-size molds after cleaning the crucible throat.

NOTE: *Do not leave mold in machine over night.*

#### **22—Shut Off Heaters Except Crucible Heater**

As soon as the mold is removed, shut off the "sealing" heater on electric-heated machines, and turn off the "mold housing burner" on gas-heated machines, unless another mold is to be inserted immediately.

If machine is to stand for some time, turn off all switches except control panel switch on the electric-heated machine, and turn off all burners except the "crucible burner" on the gas-heated machine.

If machine is to be shut down, then turn off all switches on the front of the machine, and the control panel switch on the electric-heated machine, and all burners on the gas-heated machine.

#### **23—Clean Mold Housing**

After the mold is removed the mold housing is well heated, this is the best time to use the mold housing scraper for thorough cleaning.

#### **EMERGENCY STOP**

It sometimes happens that the machine is stopped with the plunger in raised position, or a mold loosens from improper sealing in the starting operation. The metal in the crucible will drain out through the mold chamber or the mold under these conditions unless this emergency stop is used promptly.

#### **24—Pull Plunger Rod Clevis Pin A1319A**

The quick removable Plunger Rod Clevis Pin has been designed to permit the plunger to be lowered, regardless of the position of the machine. It is necessary only to grip the knurled head of the clevis pin and pull the pin out.

#### **25—Shut Off Motor**

#### **26—Pull Plunger Lever All the Way Up by Hand**

By pulling the handle of Plunger Lever 1315½, Plate 1, up, the plunger is forced down, closing the port. If the sealing valve is also closed, no metal can escape through the mold chamber.

### Operating Conditions

Material	Speed	* Stroke in Picas	Throat Switch	* Diameter of Water Stream	Portion of Indicator Which is Melted
1 Pt. ....	High	3	625°	1/8" or less	1/2 inch
2 Pt. Leads ....	High	6	600°	1/8" or less	1/2 inch
2 Pt. Rules ....	High	6	625°	1/8" or less	1/2 inch
3 Pt. or 4 Pt. Leads ....	High	6 to 7	600°	1/8" or less	1/2 inch
3 Pt. or 4 Pt. Rules ....	High	6	625°	1/8" or less	1/2 inch
6 Pt. Slug ....	High	6	600°	1/8" or less	1/2 inch
6 Pt. Rule ....	High	5 to 6	625°	1/8" or less	1/2 inch
12 Pt. Slug or Rule ....	Low	4 to 6	585°	1/8" or less	1/2 inch
18 Pt. Slug or Rule ....	Low	4 to 5	575°	1/8" or less	1/2 inch

\*Due to variations in water temperature, metal and heating conditions, the stroke and water should be adjusted to individual plant conditions so that correct appearance of strip is obtained as explained on Page 11.

# Maintenance and Adjustments

## Fixed Adjustments of The Elrod

### Clamp Mechanism Adjustment

Set machine to zero position. See that Material Clamp Plate is in the machine.

The amount of travel given the Material Clamp Plate (movable)  $1326\frac{1}{2}$  is controlled by the Material Clamp Lever Fulcrum Pin 1510, Plates 10 and 11.

The fulcrum pin may be turned after loosening the Set Screw  $1326\frac{1}{2}$ , Plate 11. The proper adjustment is one that enables the clamp to just grip a piece of the thinnest material to be produced. Then lock the set screw.

### Cut-Off Eccentric Stud Adjustment

Set machine to zero position. Pull out Plunger Clevis Pin 1319A, Plates 11 and 4. See that Movable Knife Spring 1621, Plate 11, is connected to its spring studs. Move the Cutter Head to the right  $\frac{1}{4}$  inch and block it there with a strip of 18 point material inserted between the cutter head and its left stop.

Now turn the machine over until the Cut-Off Lever A3610, Plate 11, has pushed the Movable Knife 3634, Plate 11, as far toward the front as it will go. In this position the bottom of the movable knife should pass the stationary knife approximately  $\frac{1}{16}$ th of an inch.

If this adjustment is not correct, loosen Set Screw 1322 and turn the Fulcrum Pin 1510 until the bottom of the movable knife passes the stationary knife approximately  $\frac{1}{16}$ th of an inch. Then lock the set screw.

### Plunger Height Adjustment

The correct setting of the Plunger 1317B, Plate 1, is with the bottom of the plunger  $\frac{3}{16}$ ths of an inch above the top edge of the port in the well, when the plunger is at the highest point of the stroke.

Turn the machine until the plunger is at the top of its stroke, with a mold in the machine, and the water turned on.

Disconnect the Plunger Connecting Rod 1317B, Plate 1, by pulling out Plunger Connecting Rod Pin 1318B, Plate 1.

Take a piece of  $\frac{1}{16}$ th inch rod and bend a right angle at one end about  $\frac{3}{8}$ ths inch long. Push the rod down in the molten metal between the heating element and the rear wall of the well. Turn the rod so it enters the port hole.

Pull the rod up tightly against the top edge of the port hole and push the plunger down so it touches this rod. This lines up the bottom of the plunger with the top of the port hole.

In this position check the hole in the lever. The upper edge of the hole in the plunger connecting rod should be in the middle of the hole in the lever. If it is in this position, the plunger will be  $\frac{3}{16}$ ths of an inch above the port hole when connecting rod and lever are connected.

If the holes are not in position as described above, loosen the Check Nut 1113 $\frac{1}{2}$ , Plate 1, at the top of the Plunger Lever Rod and screw the Plunger Rod Clevis 1316A, up or down as required.

### Plunger Spring Adjustment

The distance between the bottom of Plunger Rod Clevis 1316A, Plate 1, and the top of Plunger Spring 1323, Plate 1, is  $3\frac{3}{8}$  inches for all ordinary operations.

The Adjusting Nut 1113 $\frac{1}{2}$ , Plate 1, which is on top of the plunger spring, is adjusted up or down for the following conditions:

Sometimes conditions are improved on 1 point material and 2 point hairline by increasing the plunger pressure. When this is required, turn adjusting nut down, so there is a clearance of about  $3\frac{3}{8}$  inches between the bottom of plunger rod clevis and the top of plunger spring.

When new cored molds are used it is advisable to reduce the plunger pressure. When this is required, turn adjusting nut up so there is a clearance of about  $2\frac{3}{8}$  inches between the bottom of plunger rod clevis and the top of plunger spring. When cored molds have been in use for some time, use the standard  $3\frac{1}{8}$  inch adjustment.

#### **Stationary Knife Adjustment**

Remove Plunger Rod Pin 1318B. Turn machine over by hand until movable knife is as far forward as it will go. Loosen the two Stationary Knife Holding Screws 3633, Plate 11, move knife to the left, and insert two thicknesses of newsprint between the movable and stationary knives. Move the stationary knife to the right until it is bearing against the two thicknesses of newsprint and movable knife, hold in this position and tighten the two movable knife screws. Turn machine to zero position and remove the newsprint. Replace the Plunger Rod Pin.

CAUTION: See that the cut-off eccentric stud is properly adjusted so that the bottom of the movable knife just passes the stationary knife at the farthest point of its travel.

#### **Gas Thermostat Adjustment**

Turn off all burners except the crucible burner. Place a thermometer in the crucible and adjust the Gas Governor Adjusting Screw EC1816, Plate 5, as necessary to obtain a temperature between  $585^{\circ}$  and  $600^{\circ}$  F.

### **Maintenance of The Elrod**

#### **Crucible Throat Cleaning**

The crucible throat behind the mold housing should be cleaned every month to keep this metal passage free from dirt and dross.

A  $\frac{3}{8}$  inch Star Drill 12 inches long can be used for cleaning the small opening from the mold housing to the crucible well. This drill is inserted in the opening. While rotating the drill, tap gently with a small hammer to remove any accumulation of carbon or dross. Be sure to remove these particles before resuming operation by opening and closing the sealing valve and allowing metal to flow into the drip cup.

When molds are difficult to insert or remove, a thorough cleaning of the mold housing is indicated.

#### **Diffusion Tube Care**

##### **Installing a Diffusion Tube**

The Diffusion Tube 1281C, Plate 7, fits into a standpipe on the right of the crucible. The top of this standpipe is above the level of the metal in the crucible. There is an Adapter 1332 $\frac{1}{2}$ D, Plate 7, between the diffusion tube and the standpipe that serves as an inexpensive wearable piece.

The diffusion tube should be put in when the crucible is hot, and the inside threads of the adapter should be well graphited. Then insert a wire into the hole at the top of the tube and keep filling this hole with Elrod mold oil, slowly removing the wire until the tube is entirely full. Connect the Feed Line 3261, Plate 7, at the oiler and the diffusion tube. With the shut-off valve closed, raise the end of the pressure adjusting lever until it stops. This will charge the oiler. Now loosen the union at the top of the diffusion tube one turn, and open the shut-off valve slowly so that oil and bubbles of air will be forced out of the end of the oil feed line. As soon as the air stops coming out, close the shut-off valve and tighten the union. The diffusion tube is now ready to operate. Remove all excess oil.

##### **Removing a Diffusion Tube**

The best time to do this is just after a mold has been removed, as the standpipe is at its hottest and all metal in the standpipe is molten. Close the shut-off valve, disconnect the union on top of the diffusion tube, loosen the union at the other end of the feed line, and swing the feed line out of the way. Then unscrew the diffusion tube.

##### **Cleaning a Diffusion Tube**

After a diffusion tube has been in service for some time, there will be a deposit of dross and dirt around the lower end of the tube, which may interfere with the proper flow of oil, requiring higher oil pressure to operate.

When this condition exists, remove the diffusion tube, scrape off the deposit from the outside of the tube, remove the screw in the

bottom of the tube and clean out the threads in the screw as well as the threads in the lower part of the tube, using a 10x30 Tap. Replace the screw and tighten firmly. Do not disturb the asbestos packing in the tube.

#### **Packing a Diffusion Tube**

After the diffusion tube has been in steady service for some time (usually a matter of several weeks), it may develop that the oil does not feed quite fast enough. When this happens return the diffusion tube to the Ludlow Typograph Company at Chicago, Illinois, for repacking, or repack it with a Repacking Set AEC1720A. Instructions are sent with the repacking set. Have spare tubes on hand for replacement.

#### **Oil to Use in Diffusion Tube**

Use Elrod mold oil only. It is sold by the Ludlow Typograph Company in 1 and 5 gallon cans, is red in color, and especially prepared for the purpose. Keep oil can closed, as dirt seriously interferes with the operation of the diffusion tube.

#### **Prevent Drying Out of Diffusion Tube**

If the Elrod is kept heated, but not operating, the diffusion tube should be removed. The tube dries out through prolonged heating without oil flowing through it.

Diffusion tubes should be well oiled before being placed in storage.

### **Gas Burners**

On account of the varying quality of gas used in different areas, a routine of regular inspection of the gas burners must be determined in each plant.

A spud in each of the burners calibrates the quantity of gas. These seldom need to be changed after installation, but the hole in them gradually becomes smaller after a year or two, and they should be cleaned or replaced.

The air mixer sleeve on the burners controls the amount of air. The proper mixture of air and gas is one that will burn clean without "popping," and that will direct the hottest portion of the flame

to the surface to be heated. A piece of  $\frac{1}{16}$  inch iron wire placed in the path of the flame will disclose the hot and dead portions of the gas flame.

### **Machine Lubrication**

Regular lubrication is imperative if the machine is to give good results for any length of time. Use a good grade of machine oil. S.A.E. 20 is a good viscosity to use.

The main shaft and counter shaft bearings are lubricated through the pressure grease fittings in back of the front panel door opening. A pressure grease gun is included with each machine, and should be filled with a good grade of cup grease. Place head of grease gun on fitting, and press handle until fitting and plastic line are filled. These fittings should be checked every week that machine is in operation.

Other moving surfaces and cam faces can be lubricated directly or by means of the oil holes provided in these parts.

NEVER USE ELROD MOLD OIL FOR LUBRICATION, as it is absolutely unfitted for this type of service.

### **Mold Care**

The sides of Elrod molds are made of fine grain cast iron. They require a thin oil film on the inner surface of the mold to permit the material to pass through the mold smoothly. This oil film will not stand up indefinitely, but will dry out if exposed to the air any length of time, or if the mold is subjected to excessive heat in sealing or unsealing operations.

The mold should be cleaned thoroughly after removal from the mold chamber, per instructions on "How to Stop The Elrod." When cleaning a mold, do not tap it on any other surface than wood. Failure to handle the mold with care in the cleaning operation is the most frequent cause of damage.

Mold trouble is also caused by forcing starting strips into the mold, which causes damage to the inner surfaces, or by overheating the mold when it is being removed from the machine.

A mold should never be left in the mold chamber more than a very short time after the inside reaches a metal-melting temperature.

NOTE: When the water is turned off, and the throat and sealing



heaters are turned on, the operator should not leave the machine.

Molds may be easily damaged by careless handling, resulting in the production of imperfect strip material, or in extreme cases, the inability to produce any material at all from the damaged mold.

If satisfactory material cannot be obtained from a mold, it should be sent to the factory at Chicago for reconditioning. The mold should not be opened except at the factory, because of the difficulty in re-assembling without the necessary tools.

### **Mold Cooling Chamber Care**

The water in some sections of the country is highly alkaline and will in time clog the cooling chamber. If this is allowed to happen, the only remedy is to remove the water jacket blocks on the sides of the mold housing and scrape out the deposit.

As a preventive, the following method will work if it is done regularly each week-end. It will not clean out deposits that have accumulated, but will prevent other deposits from forming.

The first thing to do in alkaline areas is to insert a globe valve in the upright supply pipe, at the union.

Then obtain a bottle of cider vinegar, or in areas that have a very bad alkaline condition obtain some "boiler compound" from the plumbing supply house, power house or factory having steam boiler installations. These compounds are made to suit local conditions.

The procedure would be to shut off the main water supply valve located in the water line before water line is connected to the machine, and turn the water control valve on the front panel of the machine to "on" position.

Remove the Water Outlet Pipe 3233, Plate 8, by disconnecting the Union A301, Plate 8. Insert a small funnel in the opening on top of the mold housing, and fill with cider vinegar or boiler compound and leave it in over the week-end.

Before starting, turn the supply valve to "off" position, replace the water outlet pipe, and open the globe valve on supply pipe.

### **Plunger, Well and Sealing Valve Cleaning**

The Crucible Well 1904A, Plates 1 and 4, and Plunger must be cleaned at least twice weekly.

Upon completion of a run of material, shut the machine off, turn it to zero position, turn off the sealing and throat heaters and let the water run. It is necessary that the mold and material be in the mold chamber when the plunger is pulled out of the well, otherwise the metal in the crucible will drain out.

Lift the lock holding the Connecting Rod Pin 1318B, Plate 1, and pull out the pin. Open the sealing valve. Pull straight up on the plunger link until the plunger is nearly out of the well, then pull the plunger link slightly to the right so it will clear the plunger lever, and then lift the plunger out of the crucible. It may be necessary to press down on plunger lever handle while doing this to make it easier.

While the plunger is still hot, wipe or brush it off. If all metal and dross does not come off readily, dip the plunger in the metal, swab on some "Lubriclean" Fluid A945, and then wipe or brush again.

Place the Crucible Well Cleaning Tool in the molten metal until it is thoroughly heated, and then swab some "Lubriclean" on the surface of the tool, and insert it in the crucible well. Operate the cleaning tool with an oscillating and up-and-down motion the full length of the crucible well, removing the cleaning tool frequently to wipe off the accumulated dross. Apply more "Lubriclean" each time the tool is wiped. Repeat this operation until no trace of dross remains.

Skim the dross and "Lubriclean" residue from the metal in the crucible, and apply a thin coat of "Lubriclean" to the outer surface of the plunger and replace it in the well. Move the plunger up and down a few times by hand to see that it moves freely. If it does not, repeat the cleaning process.

If the turning of the Sealing Valve becomes sluggish or difficult, clean it also when the plunger is cleaned.

To remove the sealing valve, back off the retaining screw as far as it will go. This screw faces toward the front of the sealing valve bracket. Then remove the sealing valve, clean it with a rag, and coat with "Lubriclean" and replace it in position in the well, rotating it several times until it turns freely. Remove and repeat the process, and then screw in the retaining screw as far as it will go.

The Plunger Cleaning Outfit consists of a heatproof Swab 946A, a stiff Brush 943, a Mold Housing Scraper AEC1715B, and a quart of "Lubriclean" A945.

These tools, together with the Crucible Well Cleaning Tool, should be used for cleaning the plunger, well and mold chamber.

"Lubriclean" may be used to lubricate all of the hot parts on the Elrod, as it is especially made for use at high temperature.

#### **Pressure Oiler Care**

After the pressure oiler has been in service for some months, it may be necessary to replace the leather packing at the bottom of the piston.

With the Shut-Off Valve A1259A closed, remove the Adjusting Lever Fulcrum Screw 230, Plate 7, to permit sliding the Adjusting Lever 1277B, Plate 7, through the slot in the Piston Pin AEC1268.

Remove the three screws which fasten the cover to the oiler body, and the piston may be pulled out of the cylinder. Remove the screw, retaining washer and worn leather packing from the lower end of the piston. Put on a new leather packing and reassemble, tightening the screw very lightly.

Insert the piston in the well and move it up and down a few times to centralize the packing. Pull the piston out and tighten the screw firmly, being careful not to move the leather packing.

Replace piston, cover, screws, adjusting lever and weight. Put Elrod mold oil in the oil cup and pump the adjusting lever up and down, and continue to put oil in the cup until it remains full, after pumping. Then loosen the union at the top of the diffusion tube one turn, and open the shut-off valve slowly so that the oil and bubbles of air will be forced out of the oil feed line. As soon as the air stops coming out, close the shut-off valve and tighten the union. The oiler is now ready to operate. Remove excess oil.

### **Electrical Troubles of The Elrod**

#### **Test Lamp**

A Test Lamp A932A is the most convenient and time-saving tool for locating electrical trouble in the crucible. This test equipment

consists of a red prod containing a neon glow lamp, and a black prod and attachment plug. When plug is in the receptacle, it is short-circuited. Plug is taken out of this receptacle and plugged into the electrical supply line (90 to 600 volts) for some tests, as indicated in following instructions.

The red prod containing the neon glow lamp is the live test point. Check the test lamp by touching the red prod to a ground. If the neon lamp does not light, remove the plug from the receptacle and reverse points. Recheck.

#### **How to Use Test Lamp**

The test lamp may be used to locate a "ground," and "open circuit," a "short circuit," or a "dead" heating element. An explanation of these terms follows:

##### **Ground**

An electrical connection between an electrical circuit and the crucible or frame of the machine.

##### **Short Circuit**

A connection between the two sides of a circuit so that the current takes a shorter path than intended.

##### **Open Circuit**

An incomplete circuit, one broken at any point, so that current does not flow through any part of it. A broken wire or loose connection can cause an open circuit.

##### **Dead Heater**

A heater that has an open circuit.

#### **Fuse Test**

Place the fuse to be tested on a piece of dry paper or wood. Connect test lamp to lighting circuit, and place a test point on each end of the fuse. If test lamp lights, the fuse is o.k.

CAUTION: In making the tests described on pages following, note carefully whether the test points are to be placed on "wires" or "terminals."

### **Preliminary Tracing of Electrical Trouble**

Indication of electrical trouble will be variations of temperature or stopping of machine. Variations of temperature have to do with the crucible, side throat or sealing heaters. Stopping of the motor is confined to the motor circuit.

#### **Fuses**

The first source of trouble to look for is in the fuses. Turn off the main switch. There are four sets of fuses, as indicated on the bus bar insulator board directly below the fuses. From left to right, the first three or second and third fuses are the motor fuses, depending on whether operated on single or three phase current.

The next two, in order are for the sealing heaters, crucible heaters and throat heaters. Remove each set of fuses independently and check with the test lamp. Be sure that the fuse used for replacement has the same amperage rating as the one replaced. Check fuse clips for good spring tension.

If the fuses are good, the trouble may be in the wiring or in the units themselves. To check heating units and wiring, turn main switch to "Off" position and remove the fuses. With test light plugged into the light circuit, place points on upper fuse clips. Turn heater switch or thermostat to "On" position. If the heating units and wiring are satisfactory, the neon light in the test prong will glow. When circuit is not complete, remove covers at front of crucible and check units and wiring direct.

#### **Crucible Heater Circuit**

If the metal in the crucible fails to melt out, check the crucible heating unit fuses. If they are found satisfactory, remove fuses and check in the same manner as throat and sealing units. The connections of the crucible heating units to the wiring are at back of crucible covered by inspection plate.

#### **Motor Circuit**

If the motor fails to start, slows down, stops, or overheats, it is an indication of trouble in the motor or motor circuit. Before making any tests, take off the belt and see if the trouble persists. If motor

runs satisfactorily with the belt removed, then look for mechanical trouble in the machine. When motor does not run, first check the motor fuses. If they check out satisfactorily, make sure there is power at the motor terminals. This can be done by closing motor switch and using test light with plug inserted in the test lamp.

#### **How to Calibrate the Thermostats**

If for any reason you find that the temperature reading on the dial of the crucible thermostat does not correspond to the reading of the temperature of the type metal in the crucible, calibration may be made by pulling forward on the dial to remove it and by loosening the two small screws on the front of the hub. The small slotted and indexed dial may be rotated toward "R" to raise, or toward "L" to lower the temperature of the type metal. The indicator lamp above the dial should go on at the temperature reading of the thermometer. To adjust the thermostat of the throat heating units, set the indicating knob so that the neon light will go out at the same temperature setting as the crucible thermostat.

### **Mechanical Troubles of The Elrod**

#### **Cutter Head Sluggish**

When cutter head is sluggish in its return, setting of Adjusting Nut 3644, located on Cutter Rod Bracket 3603, should be checked. To increase tension, turn Nut 3644 clockwise from "A" to "B," "C" or "D." To relieve tension when casting the smaller size materials, reverse procedure is required.

If there is a definite bind on the cutter head rod, check the following:

Accumulation of dirt or metal chips between the stationary knife and the material table.

Lack of lubrication on the cutter head guide rod and cut-off gauge rod.

Cutter head guide rod bent or out of line. To check this adjustment, remove Adjusting Nut 3644 and spring, pull guide rod to the right and release. If guide rod fails to return freely, check for straightness.

#### **Hairline Rule Broken**

Occasional breaks may be noticed in the face of rules. The cause of this usually may be determined by noticing whether the breaks are sharp or round in character.

Rounded edges indicate that too much oil is being used, or that the oil is not properly distributed over the entire surface of the strip. This may be corrected by shutting off the oil supply for a short time, or by a reduction of heat, or by an increase in water flow.

Sharp breaks are caused by a lack of oil or too long a stroke. Other causes may be from a damaged mold, or from improper heating or cooling conditions.

#### **Machine Jams and Stops**

It sometimes happens that the machine jams or stops with the plunger in a raised position, or a mold loosens from improper sealing in the starting operation. All the metal in the crucible will drain out through the mold chamber or the mold under these conditions, unless prompt action is taken.

When this happens, grasp the knurled head of the Plunger Rod Clevis Pin A1319A, Plate 1, and pull the pin out. Then pull the handle of the Plunger Lever 1315½, Plate 1, all the way up by hand, and shut off the motor.

By pulling the plunger lever up, the plunger is forced down, closing the port. If the sealing valve is also closed, no metal can escape through the mold chamber.

#### **Material is Bowed**

The operator should be careful to clean off the underside of the mold and the bottom of the mold chamber before inserting the mold, and hold the mold firmly against the bottom of the mold chamber and parallel to the sides of the mold chamber while the sealing is taking place, and thereby avoid the experience of producing "bowed" material.

When sealing a mold, it is advisable to lay a strip of 2 point on the material table and let the right end of the starting strip rest on it. This tends to keep the mold parallel to the bottom of the mold chamber.

A defective mold or improper lubrication can cause bowed material. If either the top or bottom of the strip is lubricated while the opposite edge is dry, this will cause a stretching of the material along the dry edge and will produce a bowed strip.

An abnormal amount of water will cause the material to bow. Check water flow to the proper amount.

If the material is bowed down or concave as delivered, and lubrication and water are apparently o.k., it is an indication that the mold is improperly sealed, and this operation will have to be done over.

If the material is bowed up, or convex as delivered, and lubrication and water are apparently o.k., it will be necessary to adjust the Material Guide Roller 3529, Plate 10, by means of the Adjusting Screw 3527, Plate 10, so the roller will press down on the material and straighten it.

#### **Material Buckles**

When producing the thinner point sizes, such as 2 point twin, and one or both strips buckle between the mold and the pulling mechanism, it indicates that the pulling mechanism is not releasing properly after the material has been pulled to the right. This may be due to metal or other material adhering to the Puller Wedge or to the sliding Release Plate.

These parts should be removed and thoroughly cleaned, making certain that the release plate slides freely back and fourth.

If the trouble continues after cleaning, the Material Clamp Plate (movable) A3445 or A3450, Plate 9, may not be properly adjusted. Check the instructions for "Clamp Mechanism Adjustment."

Another possibility is that Material Clamp Spring 1504 is broken. This is housed within Material Clamp Bracket 3501, Plate 10.

#### **Puller Slide Removal**

Remove the three screws beneath the table holding the Puller Mechanism. Remove the Positive Return Mechanism A3407 from the puller slide. With the plunger down, plunger pin out, and the puller slide to the extreme left, lift the puller slide mechanism up to remove.

NOTE: If the above cannot be accomplished easily, due to binding, then remove the clamp bracket by removing the two screws beneath the table, and with the cutter head pushed to the extreme right, lift the clamp bracket off. Then lift the puller mechanism up to remove.

The puller slide can then be moved toward the left, and pulled straight up and out when it reaches the proper position.

#### **Puller Wedge Slips**

Sometimes when starting, the first few strokes will carry too much oil, which frequently causes the puller wedge to slip. If it continues to slip, the puller wedge can be helped along by pressing toward the left on the wedge at each stroke until the oil disappears from the puller wedge and from the strip of material.

#### **Shearing Pin Breaks**

The Shearing Pin 1318B, Plates 1 and 4, which connects the plunger lever and the plunger connecting link, is made of soft steel and is so designed that should the machine be turned on while the metal in the crucible is solid, this pin will be sheared, thereby preventing damage to the machine. If this pin is sheared while the metal in the crucible is molten, it is an indication that the plunger and well need cleaning, and this should be done before another shearing pin is used.

#### **Stationary Knife Jamming**

If instructions for adjusting the stationary knife are not carried out as shown in "Fixed Adjustments," it may result in improper cut-off and/or jamming of cut-off mechanism.

## **Parts List and Numerical Index**

---

PLATE 1—Electric Crucible Parts

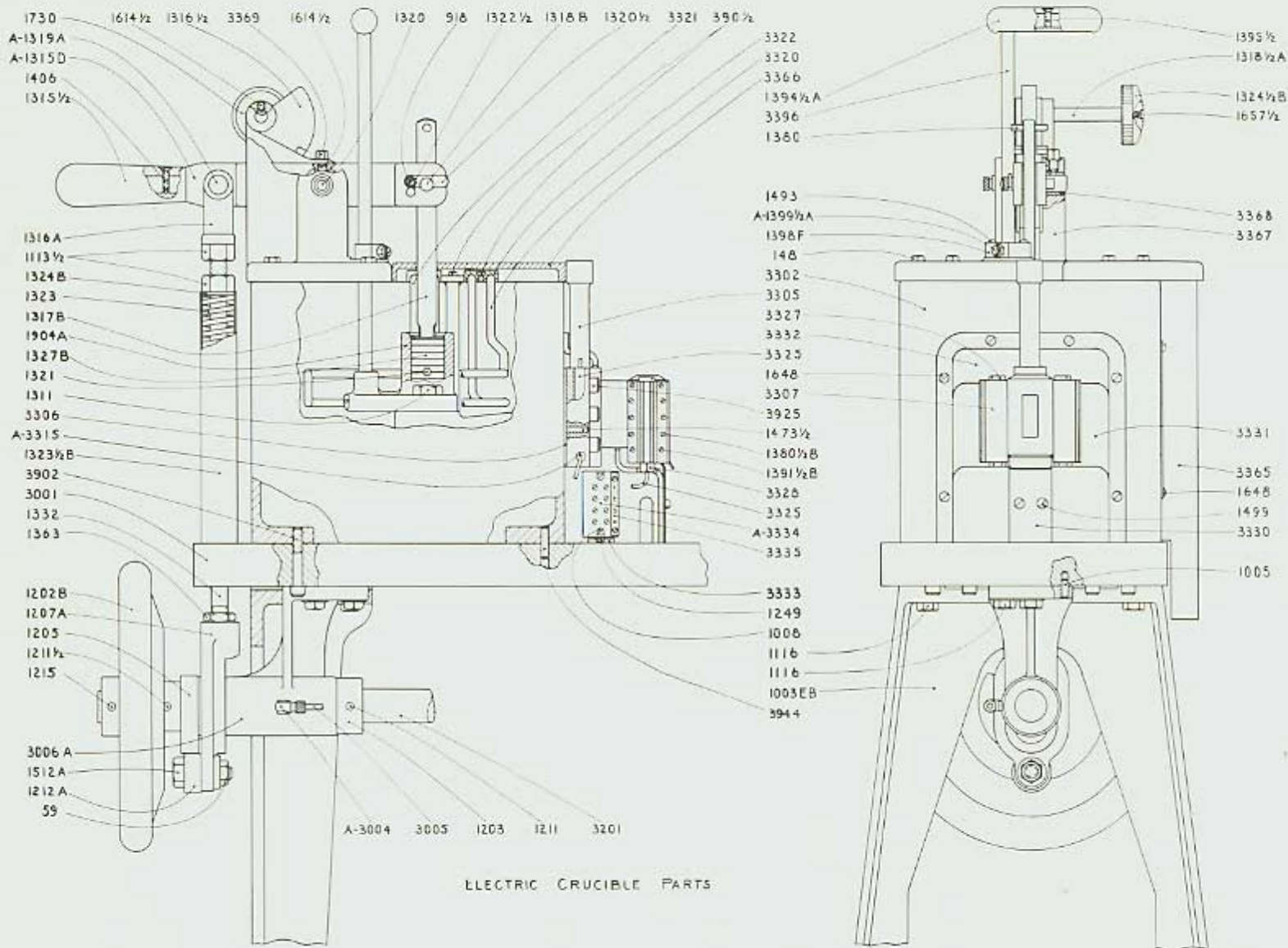

Part No.	Description
42	Style 3, 1/2"-13 Hexagon Head Cap Screw x 1" long
59	Style 101, 1/2"-13 Thick Hexagon Nut x 5/16" thick
148	Style 3, 5/16"-18 Hexagon Head Cap Screw x 1 1/4" long
390 1/2	Style 45, 10-32 x 3/4" Hexagon Socket Cap Screw
717	Style 56, 1/4" round x 1" Dowel Pin
918	Slug Pusher Cam Stud
1003EB	Leg (Left Hand)
1005	Style 56, 1/4" Dowel Pin x 3/4" long
1113 1/2	Style 101, 3/8"-11 Hexagon Nut
1116	Style 3, 1/2"-13 Hexagon Head Screw x 1 1/4" long
1202B	Main Shaft Handwheel
1203	Main Shaft Collar
1205	Plunger Cam
1207A	Plunger Lever Rod Yoke
1211	Style 55, No. 5 Taper Pin x 2" long
1211 1/2	Style 55, No. 5 Taper Pin x 1 7/8" long
1212A	1 1/2" Dia. x 7/8" long Cam Roll
1215	Style 55, No. 5 x 2 1/4" long Taper Pin
1249	Style 8, No. 10-32 Flat Head Screw x 3/8" long
1311	Style 3, 1/4"-20 Hexagon Head Screw x 1 1/4" long
A1315D	Plunger Lever Assembly
1315 1/2	Plunger Lever Handle
1316A	Plunger Rod Clevis
1316 1/2	Plunger Lever Lock
1317B	Plunger Connecting Rod
1318B	Plunger Rod Pin
1318 1/2 A	Plunger Lever Lock Shaft
A1319A	Plunger Rod Clevis Pin
1320	Plunger Lever Bracket Pin
1320 1/2	Plunger Rod Pin Retainer
1321	Style 56, 5/16" Dowel Pin x 1 1/8" long
1322 1/2	Plunger Rod Pin Retainer Washer
1323	Plunger Spring
1323 1/2 B	Plunger Lever Rod Sleeve
1324B	Plunger Spring Washer
1324 1/2 B	Valve Wheel
1327B	Plunger
1332	Plunger Lever Rod
1363	Style 101, 3/8"-11 Hexagon Nut x 3/8" thick
1380	Style 56, 5/16" Dowel Pin x 2 1/8" long
1380 1/2 B	Water Jacket Cover Screws
1391 1/2 B	Water Jacket Cover Screws
1394 1/2 A	Sealing Valve Stem Handle
1395 1/2	Style 8, No. 8-36 Flat Head Screw x 3/8" long
1398F	Sealing Valve Bearing



## ELECTRIC CRUCIBLE PARTS

Part No.	Description
A1399½A	Sealing Valve Retainer Assembly
1406	Style 8, 10-32 x ¾" long Flat Head Machine Screw
1473½	Style 56, ¾" Dia. x 1¼" Dowel Pin
1493	Style 2, 8-32 x ¾" long Fillister Head Cap Screw
1499	Style 7, 10-32 x ¾" long Oven Head Screws
1512A	Material Clamp Cam Roll Stud
1614½	Style 4, 5/16"-18 Bristo Cup Point Set Screw x ½" long
1008	Style 7, No. 10-32 Round Head Screw x 1" long
1648	Style 7, No. 10-32 Round Head Screw x ½" long
1657½	Style 8, 10-32 x ½" long Flat Head Screw
1730	Fiber Washer
1904A	Crucible Well
3001	Main Frame
A3004	Elbow Connector
3005	L.H. Bearing Grease Tube
3006A	Main Shaft Bearing Bracket (Left)
3201	Main Shaft
3302	Crucible Electric
3305	Mold Housing
3306	Mold Housing Gasket
3307	Water Jacket Cover Electric
A3315	Thermostat (Crucible & Throat)
3320	Crucible Heater Right Hand
3321	Crucible Heater Left Hand
3322	Crucible Heater Clamp
3325	Firerod Heaters Throat & Sealing
3327	Heater Cover Screws
3328	Heater Retaining Screws
3330	Drip Guard
3331	Mold Housing Cover (Right Hand)
3332	Mold Housing Cover (Left Hand)
3333	Terminal Block Bracket
A3334	Terminal Block
3335	Terminal Block Name Plate
3365	Terminal Panel Box Cover
3366	Crucible Heater Cover
3367	Crucible Cover
3368	Crucible Cover Bushing
3369	Retaining Screw
3396	Sealing Valve Stem
3902	Style 45, ¾"-16 x 2¼" long Socket Head Cap Screw
3925	¾"-24 x 1½" long Socket Head Cap Screws

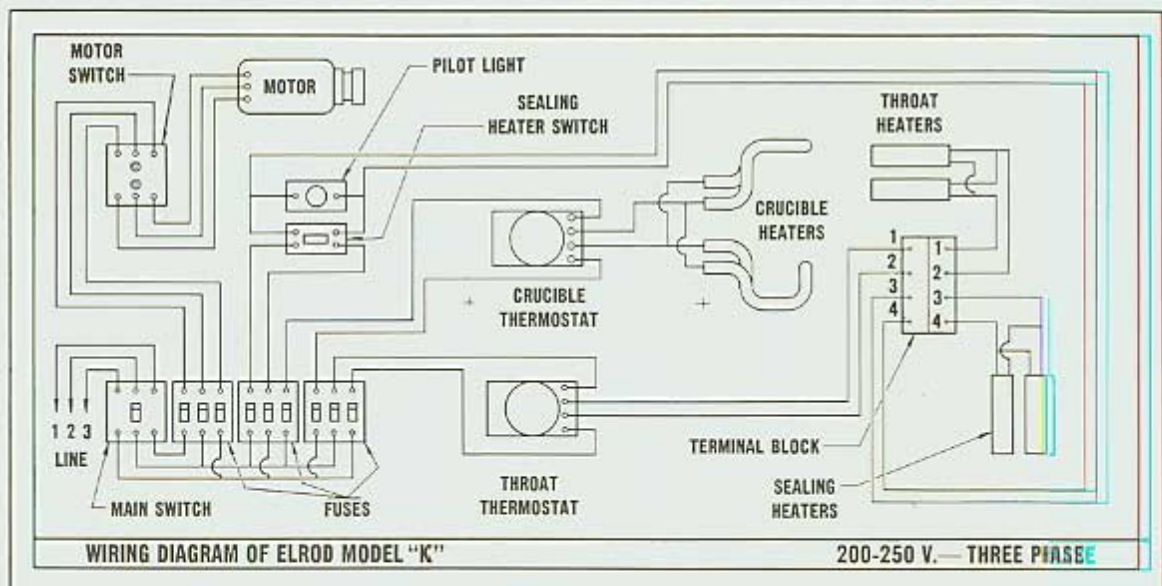
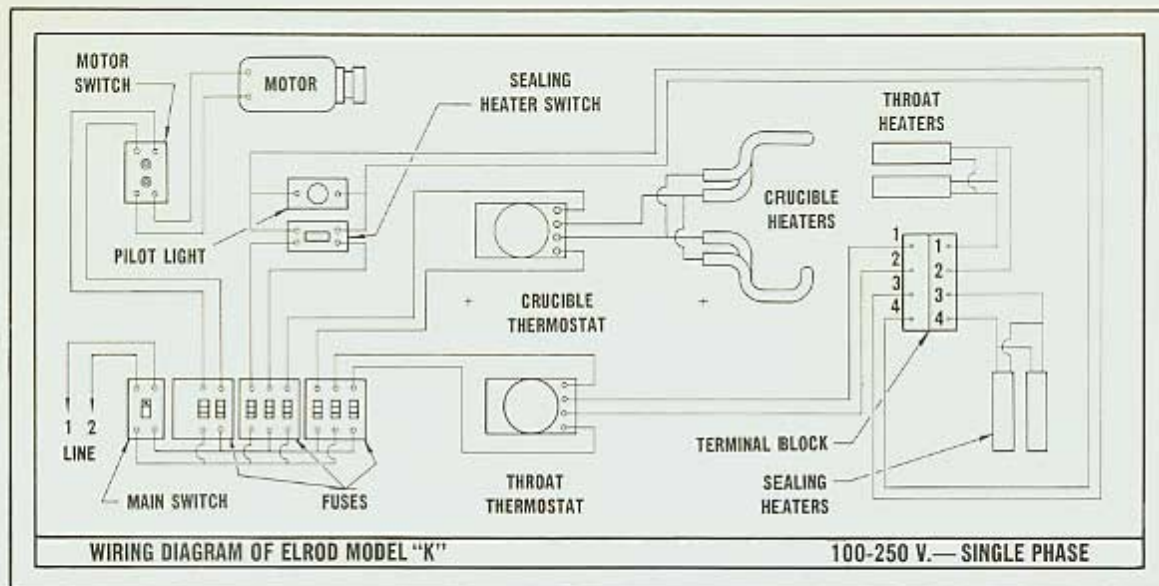

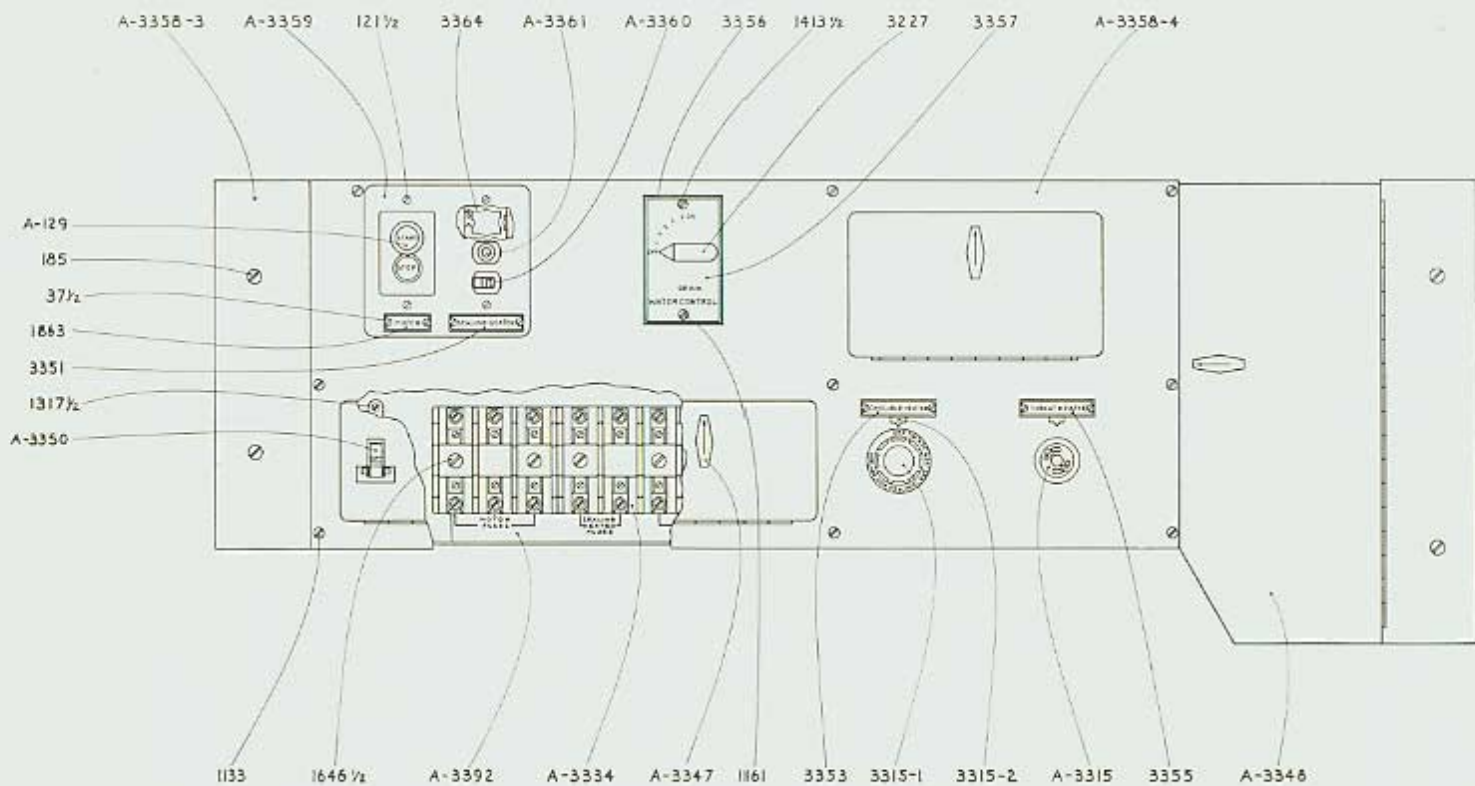

ELECTRIC PANEL BOX

Part No.	Description
37½	Name Plate Screws
121½	Motor Switch Cover Screw
A-129	Motor Switch
185	Style 7, ¼-20 x ¾" long Round Head Screw
1133	Style 7, No. 8-32 Round Head Screw x ¾" long
1161	Style 7, No. 10-32 Round Head Screw x ¾" long
1317½	Style 8, No. 6-32 Flat Head Screw x ¼" long
1413½	Style 7, 10-32 x 7/8" long R.H. Stove Bolts
1646½	Style 7, No. 10-32 Round Head Screw x ¼" long
1863	Motor Name Plate
3227	Water Valve Handle
A-3315	Thermostat (Crucible & Throat)
3315-1	Thermostat Knob
3315-2	Thermostat Neon Pilot Lamp
A-3347	Handle Knob ¼"
A-3348	Table Apron
A-3350	Switch
3351	Sealing Heater Name Plate
3353	Crucible Heater Name Plate
3355	Throat Heater Name Plate
3356	Name Plate Extension
3357	Water Control Name Plate
A-3359	Motor and Sealing Switch Flush Plate Assembly
A-3360	Sealing Heater Switch (220-volts)
A-3361	Sealing Heater Glow Lamp (220-volts)
3364	Pilot Light and Switch Mounting Strap
A-3392	Buss Bar Assembly
A-3312	Tube Block

PLATE 4—Gas Crucible Parts

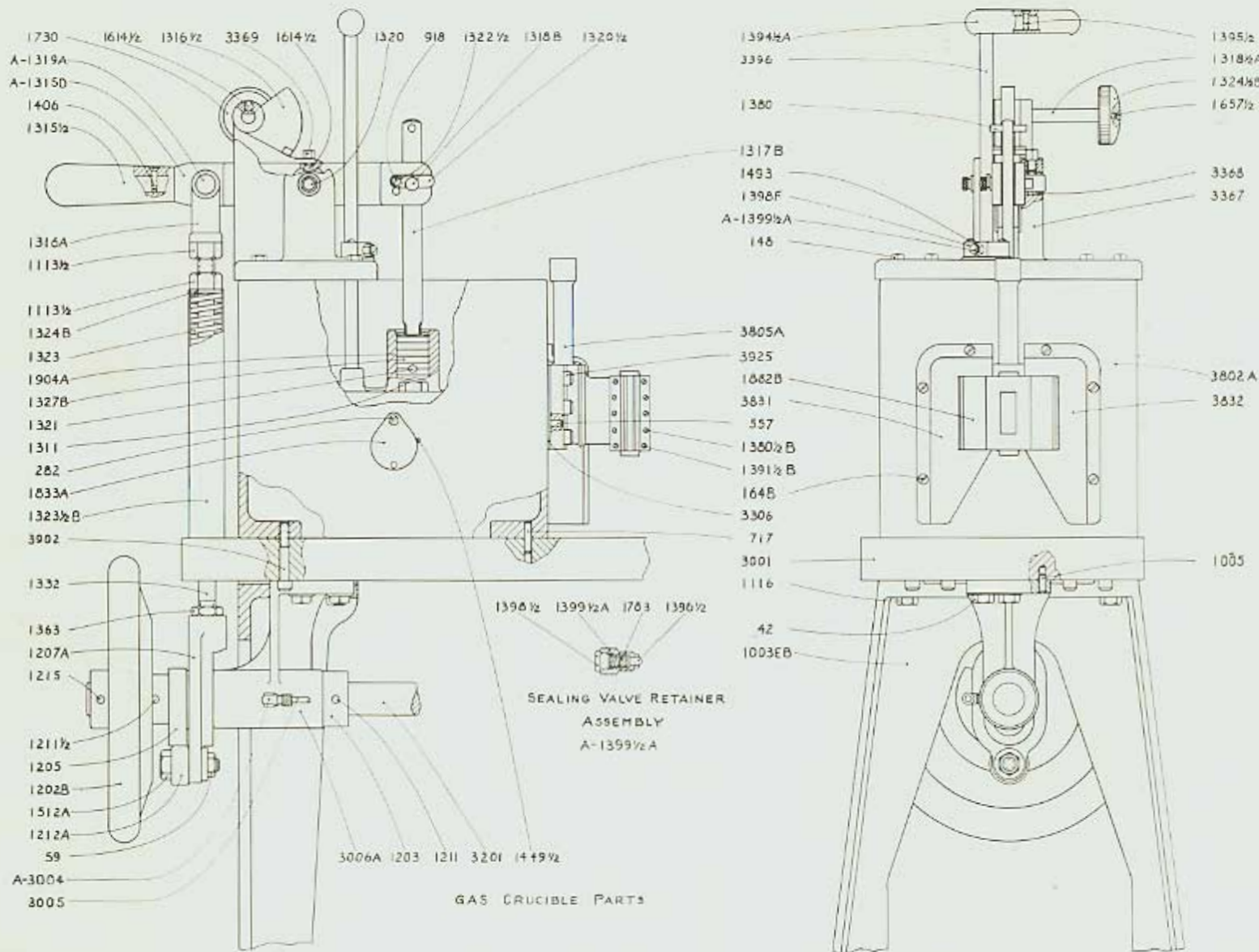

Part No.	Description
42	Style 3, $\frac{1}{2}$ "-13 Hexagon Head Cap Screw x 1" long
59	Style 101, $\frac{1}{2}$ "-13 Thick Hexagon Nut x $\frac{5}{16}$ " thick
148	Style 3, $\frac{5}{16}$ "-18 Hexagon Head Cap Screw x $1\frac{1}{4}$ " long
282	Plunger Connecting Lever Pin Holder Stud
557	Style 56, $\frac{3}{16}$ " Dowel Pin x $\frac{3}{4}$ " long
717	Style 56, $\frac{1}{4}$ " round x 1" Dowel Pin
918	Slug Pusher Cam Stud
1003-EB	Leg (Left Hand)
1005	Style 56, $\frac{1}{4}$ " Dowel Pin x $\frac{3}{4}$ " long
1113 $\frac{1}{2}$	Style 101, $\frac{5}{8}$ "-11 Hexagon Nut
1116	Style 3, $\frac{1}{2}$ "-13 Hexagon Head Screw x $1\frac{1}{4}$ " long
1202-B	Main Shaft Handwheel
1203	Main Shaft Collar
1205	Plunger Cam
1207-A	Plunger Lever Rod Yoke
1211	Style 55, No. 5 Taper Pin x 2" long
1211 $\frac{1}{2}$	Style 55, No. 5 Taper Pin x $1\frac{7}{8}$ " long
1212-A	$1\frac{1}{2}$ " Dia. x $\frac{7}{8}$ " long Cam Roll
1215	Style 55, No. 5 x $2\frac{1}{4}$ " long Taper Pin
1311	Style 3, $\frac{1}{4}$ "-20 Hexagon Head Screw x $1\frac{1}{4}$ " long
A-1315-D	Plunger Lever Assembly
1315 $\frac{1}{2}$	Plunger Lever Handle
1316-A	Plunger Rod Clevis
1316 $\frac{1}{2}$	Plunger Lever Lock
1317-B	Plunger Connecting Rod
1318-B	Plunger Rod Pin
1318 $\frac{1}{2}$ -A	Plunger Lever Lock Shaft
A-1319-A	Plunger Rod Clevis Pin
1320	Plunger Lever Bracket Pin
1320 $\frac{1}{2}$	Plunger Rod Pin Retainer
1321	Style 56, $\frac{5}{16}$ " Dowel Pin x $1\frac{1}{8}$ " long
1322 $\frac{1}{2}$	Plunger Rod Pin Retainer Washer
1323	Plunger Spring
1323 $\frac{1}{2}$ -B	Plunger Lever Rod Sleeve
1324-B	Plunger Spring Washer
1324 $\frac{1}{2}$ -B	Valve Wheel
1327-B	Plunger
1332	Plunger Lever Rod
1363	Style 101, $\frac{3}{8}$ "-11 Hexagon Nut x $\frac{3}{8}$ " thick
1380	Style 56, $\frac{5}{16}$ " Dowel Pin x $2\frac{1}{8}$ " long
1380 $\frac{1}{2}$ -B	Water Jacket Cover Screws
1391 $\frac{1}{2}$ -B	Water Jacket Cover Screws
1394 $\frac{1}{2}$ -A	Sealing Valve Stem Handle
1395 $\frac{1}{2}$	Style 8, No. 8-36 Flat Head Screw x $\frac{3}{8}$ " long
1396 $\frac{1}{2}$	Sealing Valve Lock

## GAS CRUCIBLE PARTS

Part No.	Description
1398-F	Sealing Valve Bearing
1398½	Sealing Valve Lock Screw
A-1399½-A	Sealing Valve Retainer Assembly
1399½-A	Sealing Valve Retainer
1406	Style 8, 10-32 x ¼" long Flat Head Machine Screw
1449½	Sight Hole Cover Stop Pin
1493	Style 2, 8-32 x ⅞" long Fillister Head Cap Screw
1512-A	Material Clamp Cam Roll Stud
1614½	Style 4, ⅝"-18 Hexagon Socket Cup Point Set Screw x ½" long
1648	Style 7, No. 10-32 Round Head Screw x ½" long
1657½	Style 8, 10-32 x ½" Long Flat Head Screw
1730	Fiber Washer
1783	Spring—Compression ⅞" dia. x ⅜" long
1833-A	Sight Hole Cover
1882-B	Water Jacket Cover
1904-A	Crucible Well
3001	Main Frame
A-3004	Elbow Connector
3005	L.H. Bearing Grease Tube
3006-A	Main Shaft Bearing Bracket (Left)
3201	Main Shaft
3306	Mold Housing Gasket
3367	Crucible Cover
3368	Crucible Cover Bushing
3369	Retaining Screw
3396	Sealing Valve Stem
3802-A	Crucible
3805-A	Mold Housing
3831	Mold Housing Cover (Front)
3832	Mold Housing Cover (Rear)
3902	Style 45, ⅜-16 x 2¼" long Socket Head Cap Screw
3925	⅜-24 x 1½" long Socket Head Cap Screw

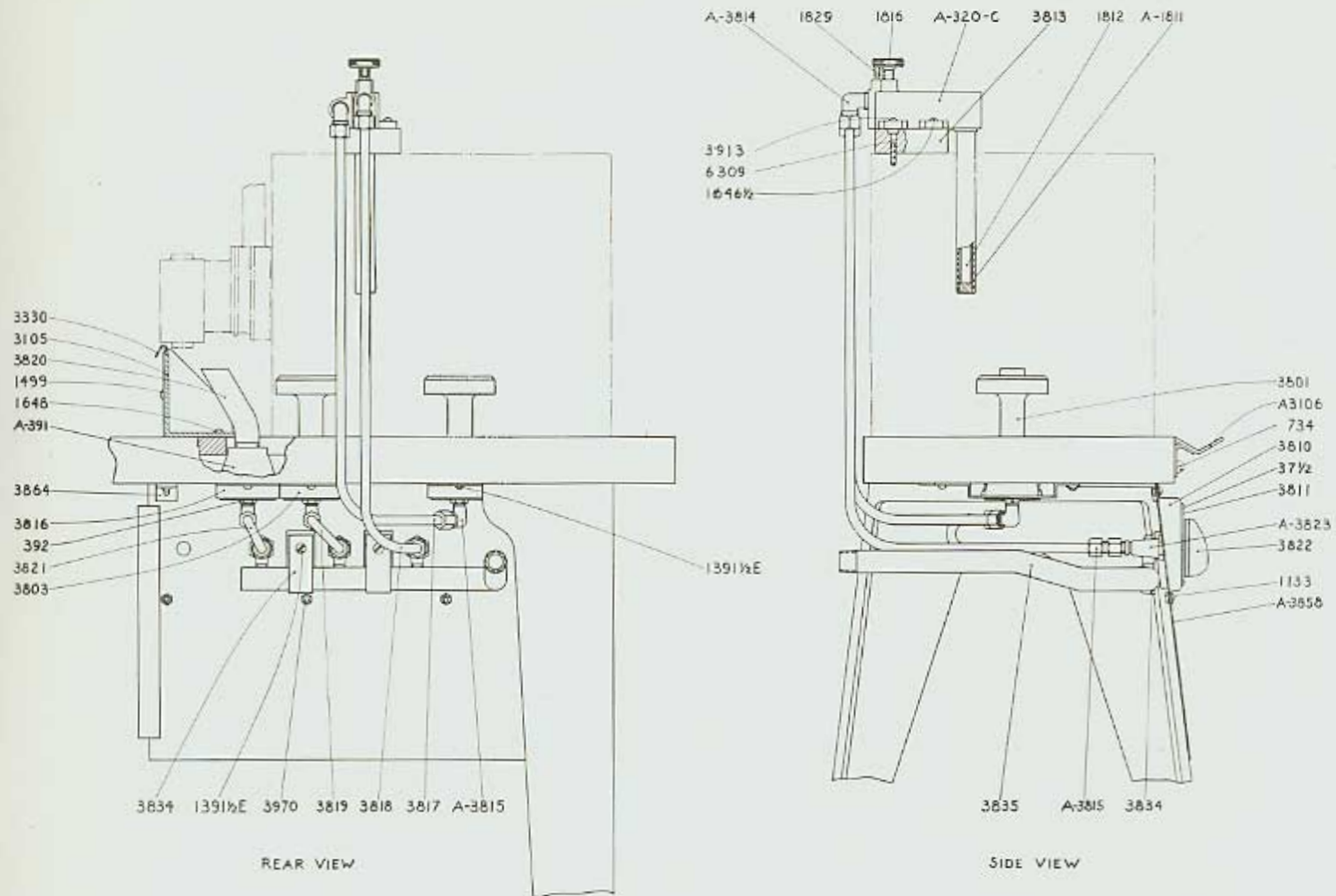

GAS HEATING SYSTEM



## GAS HEATING SYSTEM

Part No.	Description
37½	Name Plate Screws
A-320-C	Gas Governor Assembled
A-391	Gas Mixer
392	Gas Mixer Spud Adapter
734	Style 7, ¼"-20 Round Head Screw x ½" long
1133	Style 7, No. 8-32 Round Head Screw x ⅛" long
1391½E	Style 3, ¼"-20 x ½" long Hexagon Head Cap Screw
1499	Style 7, 10-32 x ¼" long Oven Head Screw
1646½	Style 7, No. 10-32 Round Head Screw x ¼" long
1648	Style 7, No. 10-32 Round Head Screw x ½" long
A-1811	Gas Governor Expansion Tube Assembled
1812	Gas Governor Carbon
1816	Gas Governor Adjusting Screw
1829	Gas Governor Adjusting Stop Screw
3105	Squirt Shield
A-3106	Splash Guard Assembly
3330	Drip Guard
3801	Gas Burner
3803	Crucible & Throat Burner Bracket
3810	Valve Cover
3811	Name Plate
3813	Space Block
A-3814	Compression Elbow— $\frac{5}{16}$ " Tube x ¼" pipe
A-3815	Compression Elbow— $\frac{5}{16}$ " Tube x ⅛" pipe
3816	Gas Burner Bracket
3817	Governor to Burner Tube
3818	Valve to Governor Tube
3819	Valve to Throat Burner Tube
3820	Sealing Gas Burner
3821	Valve to Sealing Burner Tube
3822	Gas Valve Handles
A-3823	Gas Burner Valve
3834	Manifold Clips
3835	Gas Manifold
A-3858	Fuse & Switch Box Assembly
3864	Apron Bracket
3913	Style 7, 10-32 x 1½" long Round Head Machine Screw
3970	8-32 Steel Hexagon Nuts
6309	Style 2, 10-32 x 1" long Oval Pt. Filister Head Screw

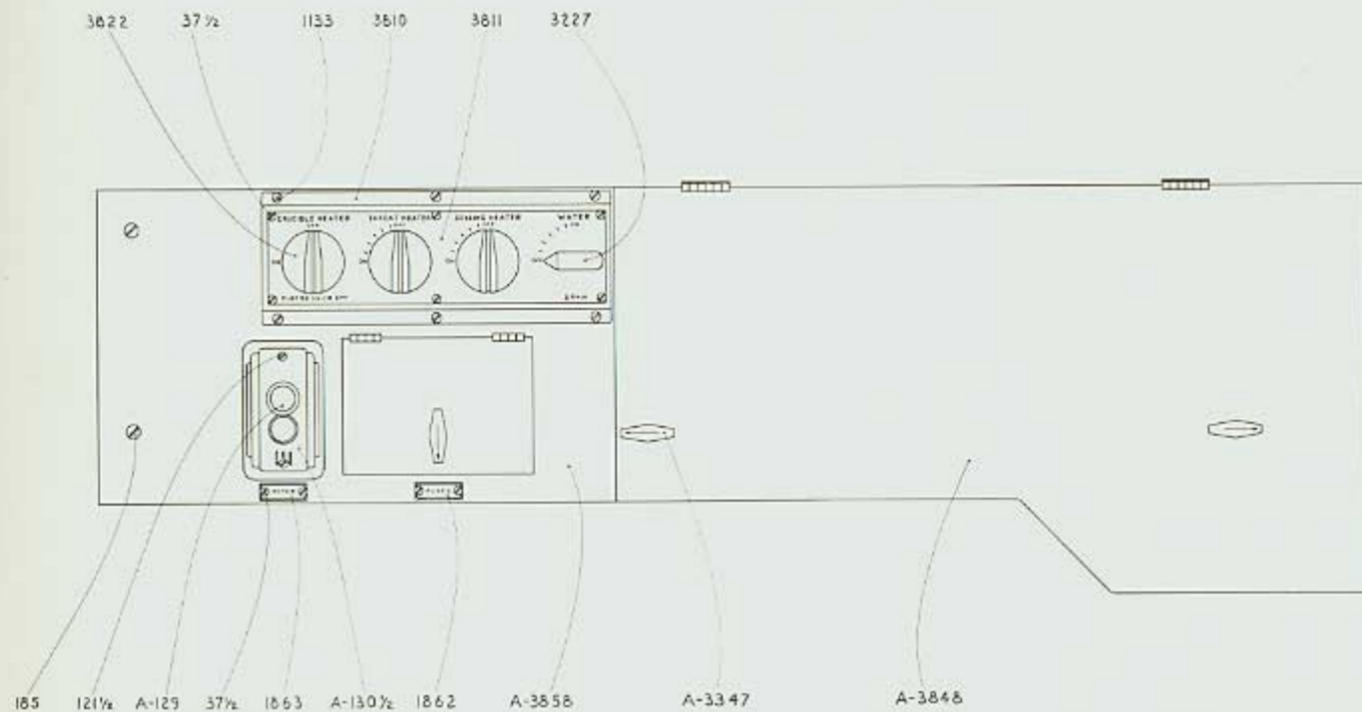

GAS PANEL BOX

## GAS PANEL BOX

Part No.	Description
37½	Name Plate Screws .....
121½	Motor Switch Cover Screw .....
A-129	Motor Switch .....
A-130½	Motor Switch Cover Sub-Assembly .....
185	Style 7, ¼-20 x ⅜" long Round Head Screw .....
1133	Style 7, No. 8-32 Round Head Screw x ⅜" long .....
1862	Fuse Box Name Plate .....
1863	Motor Name Plate .....
3227	Water Valve Handle .....
A-3347	¼" Handle Knob .....
3810	Valve Cover .....
3811	Name Plate .....
3822	Gas Valve Handles .....
A-3848	Table Apron .....
A-3858	Fuse & Switch Box Assembly .....

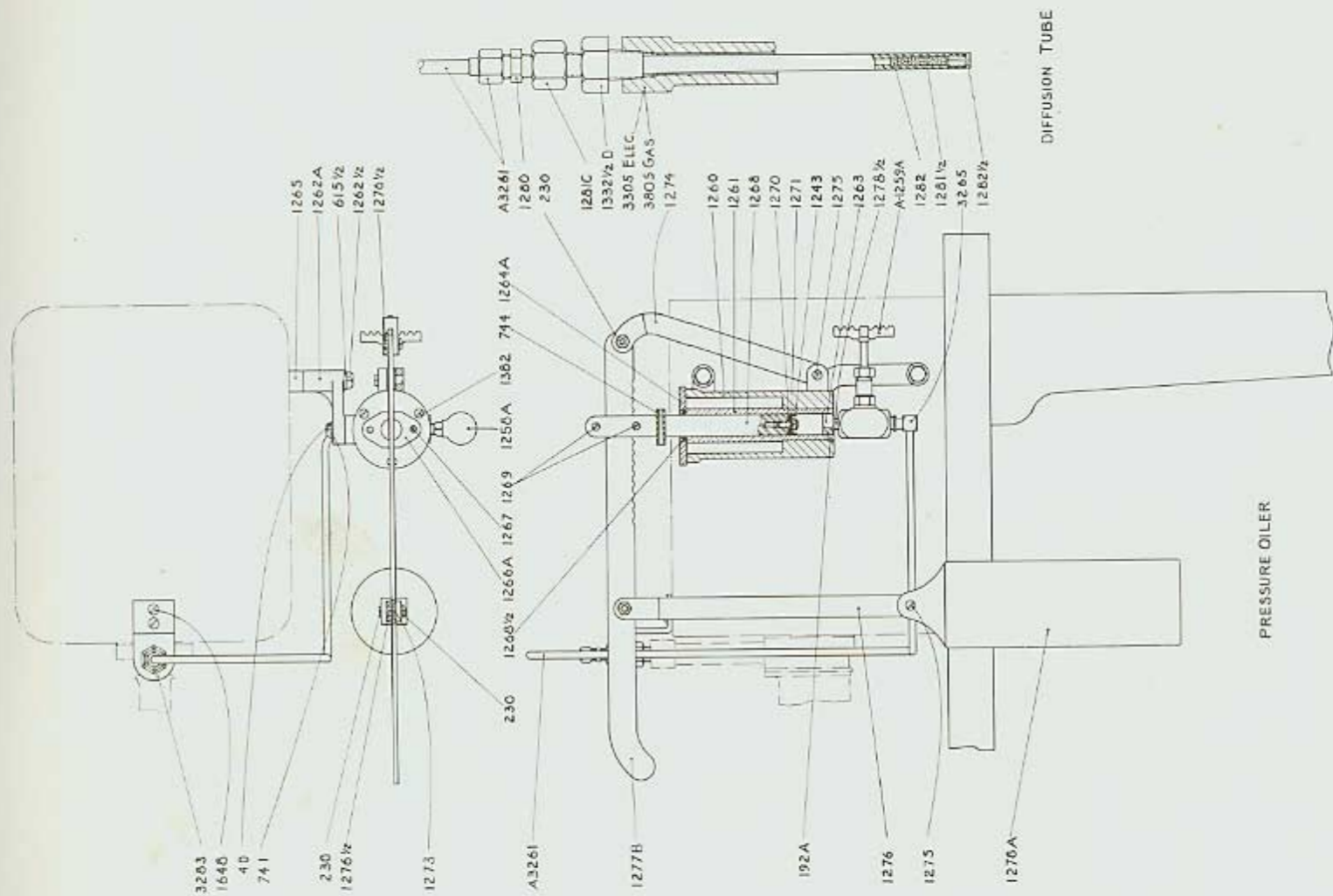

## PRESSURE OILER AND DIFFUSION TUBE

Part No.	Description
40	Style 3, $\frac{5}{16}$ "-18 x 1" long Hexagon Head Cap Screw
192-A	Style 44, $\frac{5}{16}$ "-18 x $\frac{1}{4}$ " long Hexagon Cup Pt. Set Screw
230	Style 102, $\frac{1}{4}$ "-20 Hexagon Nut x $\frac{1}{8}$ " thick
615 $\frac{1}{2}$	Style 202, $\frac{3}{8}$ " Std. $\frac{1}{8}$ " Wide x $\frac{3}{32}$ " thick Plain Lock Washer
741	Style 202, $\frac{5}{16}$ " Lock Washer
744	Style 55, No. 2 Taper Pin x $1\frac{1}{4}$ " long
1243	Style 2, $\frac{1}{4}$ "-20 Fillister Head Cap Screw x $\frac{1}{2}$ " long
1258-A	Pressure Oiler Cup
A-1259-A	Pressure Oiler Shut Off Valve
1260	Pressure Oiler Body
1261	Pressure Oiler Body Sleeve
1262-A	Pressure Oiler Bracket
1262 $\frac{1}{2}$	Style 3, $\frac{3}{8}$ "-16 x $2\frac{1}{4}$ " long Hexagon Head Cap Screw
1263	Pressure Oiler Piston Sleeve Plug
1264-A	Pressure Oiler Cover
1265	Pressure Oiler Mounting Bushing
1266-A	Pressure Oiler Piston Stop
1267	Pressure Oiler Piston Stop Stud
1268	Pressure Oiler Piston
1268 $\frac{1}{2}$	Pressure Oiler Piston Seal
1269	Shoulder Screw (for Pressure Oiler Piston and Roller)
1270	Pressure Oiler Packing
1271	Pressure Oiler Packing Retainer
1273	Style 202, $\frac{5}{16}$ " x $\frac{1}{8}$ " Lock Washer x $\frac{3}{64}$ " thick
1274	Pressure Oiler Adjusting Lever Link
1275	Shoulder Screw (for Adjusting Lever and Weight Link)
1276	Pressure Oiler Weight Link
1276 $\frac{1}{2}$	Shoulder Screw (for both ends of Pressure Oiler Adjusting Lever)
1277-B	Pressure Oiler Adjusting Lever
1278-A	Pressure Oiler Weight
1278 $\frac{1}{2}$	Pressure Oiler Feed Line Close Nipple
1280	Pressure Oiler Feed Line Connector
1281-C	Pressure Oiler Diffusion Tube
1281 $\frac{1}{2}$	Pressure Oiler Diffusion Tube Packing Pellet
1282	Pressure Oiler Diffusion Tube Packing Retainer
1282 $\frac{1}{2}$	Pressure Oiler Packing Retaining Screw
1332 $\frac{1}{2}$ -D	Pressure Oiler Diffusion Tube Adapter
1382	Style 2, No. 10-32 Fillister Head Machine Screw x $\frac{3}{8}$ " long
1648	Style 7, No. 10-32 Round Head Screw x $\frac{1}{2}$ " long
A-3261	Feed Line Tube Assembly
3265	$\frac{1}{8}$ " x 90° Street Elbow
3283	Bracket
3305 Elec.	Mold Housing (Electric)
3805A Gas	Mold Housing (Gas)

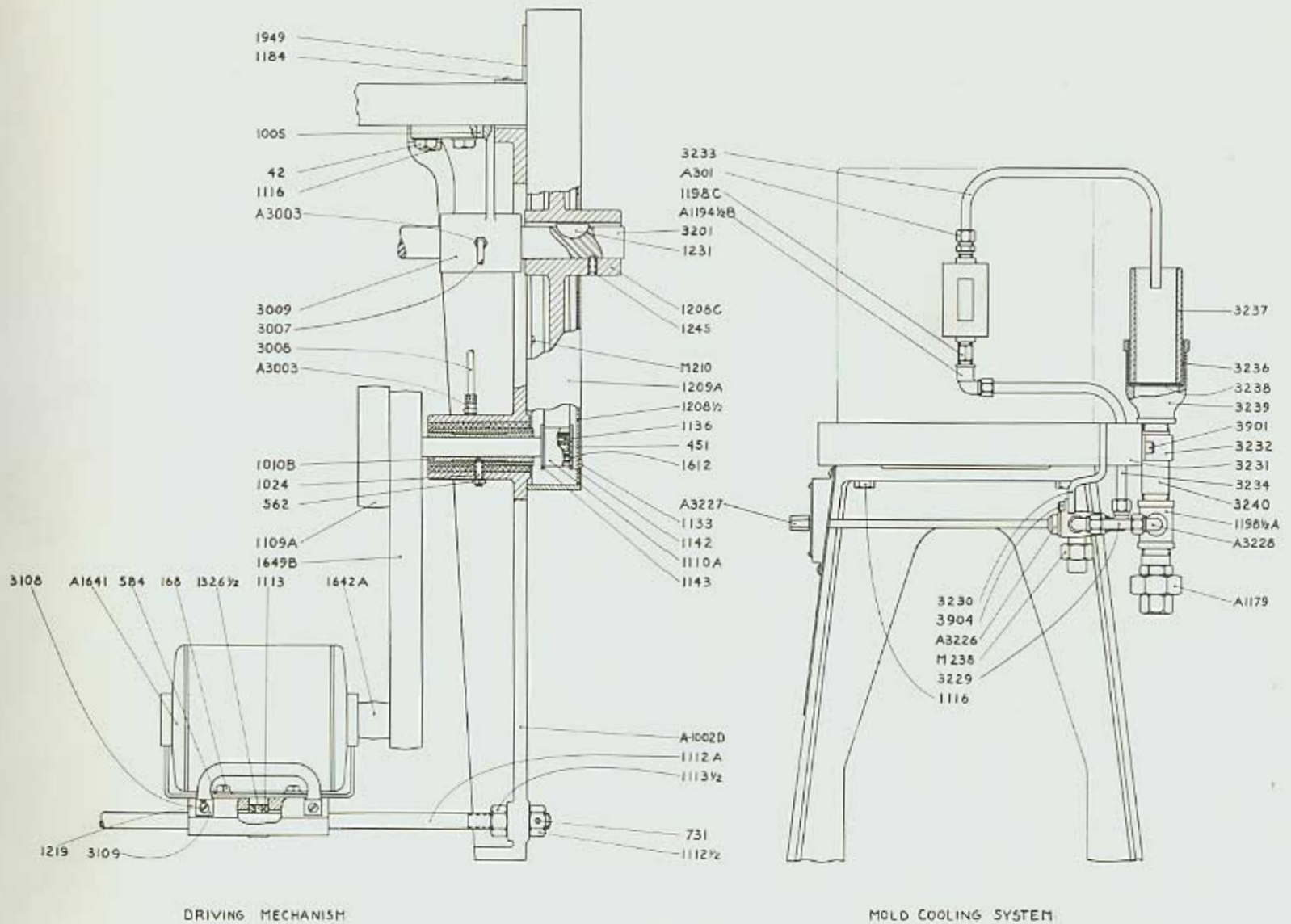

## DRIVING MECHANISM AND MOLD COOLING SYSTEM

Part No.	Description
42	Style 3, 1/2"-13 Hexagon Head Cap Screw x 1" long
168	5/16" x 18 x 1/2" Hexagon Head Cap Screw
M-210	Style 3, 5/16"-18 Hexagon Head Cap Screw x 3/4" long
M-238	Style 6, 1/4" #590 Union Elbow (Galv.)
A-301	3/8" Tube Half Union—Use A3232A for Replacements—(Heavier Duty Fitting)
451	Style 8, 1/4"-20 Flat Head Screw x 1/2" long
562	Style 102, 5/16"-18 Hexagon Nut x 3/16" thick
584	Style 201, 5/16" Washer x 1/16" thick
731	Style 55, No. 2 Taper Pin x 1" long
A-1002-D	Leg Assembly (R.H.)
1005	Style 56, 1/4" Dowel Pin x 3/4" long
1010-B	Drive Shaft Bushing
1024	Style 4, 5/16"-18 HD P Hexagon Socket Set Screw Half Dog Point Set Screw x 1" long
1109-A	Drive Shaft Pulley
1110-A	Drive Pinion
1112-A	Leg Brace
1112 1/2	Style 101, 3/8"-11 Special Drilled Hexagon Nut x 3/8" thick
1113	Motor Table Adjusting Collar
1113 1/2	Style 101, 3/8"-11 Hexagon Nut
1116	Style 3, 1/2"-13 Hexagon Head Screw x 1 1/4" long
1133	Style 7, No. 8-32 Round Head Screw x 3/8" long
1136	Drive Pinion Key
1142	Drive Pinion Flange (right hand)
1143	Drive Pinion Flange (left hand)
A-1179	3/4" Union
1184	Style 7, No. 8-32 Round Head Screw x 3/8" long
A-1194 1/2-B	Style 20, Elbow Connector 3/8" tube x 1/4" Female IPT
1198-C	Special Nipple
1198 1/2-A	Water Drain Tee
1208-C	Drive Gear
1208 1/2	Gear Guard Cover Plate
1209-A	Gear Guard
1219	Style 7, No. 10-32 Round Head Screw x 3/8" long
1231	Style 14, No. 23 Woodruff Key—5/32" x 5/16" thick
1245	Style 4, 5/16"-18 HD P Hexagon Socket Set Screw Half Dog Point Set Screw x 3/4" long
1326 1/2	Style 44, 5/16"-18 x 5/16" Hexagon Socket Set Screw
1612	Style 56, 1/8" Dowel Pin x 5/8" long
A-1641	Motor (give specifications)
1642-A	Motor Pulley (give specifications)
1649-B	Motor Belt
1949	Gear Guard Bracket
A-3003	Half Union Connector
3007	R.H. Bearing Grease Tube

## DRIVING MECHANISM AND MOLD COOLING SYSTEM

Part No.	Description
3008	Leg Bearing Grease Tube
3009	Main Shaft Bearing Bracket (Right)
3108	Motor Base
3109	Motor Table Handle
3201	Main Shaft
A-3226	1/4" Three Way Valve
A-3227	Water Valve Handle
A-3228	Compression Elbow
3229	3/8" Drain Tube
3230	Valve Bracket
3231	Spacer Block
3232	3/4" Pipe Clamp
3233	3/4" Outlet Tube
3234	3/8" Inlet Tube
3236	Spring Clip
3237	Drain Sight Glass
3238	Drain Screen
3239	Drain Cup
3240	Style 6, 3/4" x 3 3/4" Nipple
3901	Style 45, 5/16-18 x 2 1/4" long Socket Head Cap Screw
3904	Style 45, 1/4-20 x 3/4" Socket Head Cap Screw



717 6154 3981 3909 3404 3403 3427

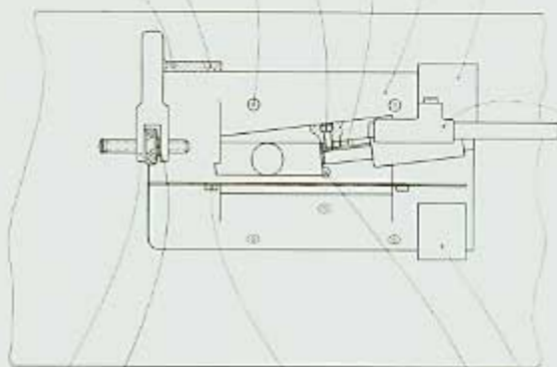

3421 3961

A-3443  
A-3450 A-3440 754 3426

3408 3428 3407 3990 295½ 3406 3409 3917 3410



PULLER WEDGE PLUNGER ASSEMBLY

3916



PULLER WEDGE SHIM

3448 3153  
3451 3455

A-3443

3986

3947

3440

3442

1441

1446



PULLER WEDGE ASSEMBLY

A-3440

3422  
3920  
3423  
3402  
3424 LEFT END  
3425 RIGHT END

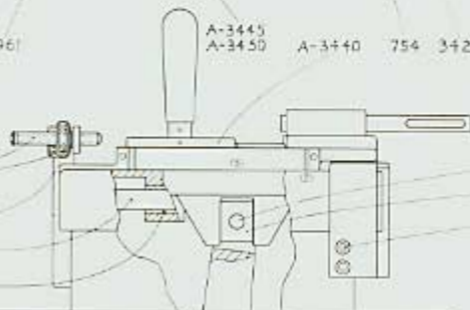

6049  
3401  
3946  
3412  
6154  
182

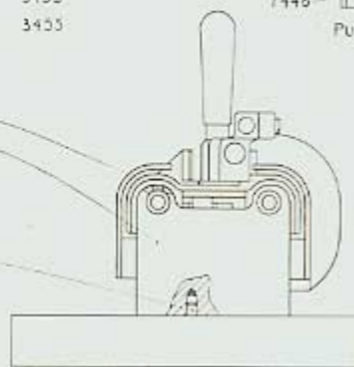

3001  
3418  
3419

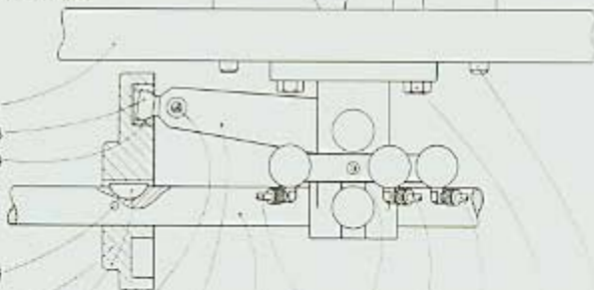

24

3206 1231 681½ 3415 3201 3005 3922 3007 3008 1108½ 3902

3414 A

1129 A-3004 3413 659½A 3416

MATERIAL PULLER MECHANISM

Part No.	Description
24	Style 55, No. 5 Taper Pin x 2½" long
182	Style 56, 5/16" Dowel Pin x 1¼" long
295½	Spring
659½-A	Style 44, ¼"-20 x ¾" long Hexagon Socket Oval Point Set Screw
681½	Style 4, ¼"-20 Hexagon Socket Set Screw x ½" long
717	Style 56, ¼" round x 1" Dowel Pin
754	Style 56, 3/16" Dowel Pin x 7/16" long
1108½	Style 3, ½"-13 Hexagon Head Screw x 1½" long
1129	Drive Shaft Grease Cup
1231	Style 14, No. 23 Woodruff Key—9/32" x 5/16" thick
1441	Slug Puller Wedge Ball
1446	Style 56, Puller Wedge Ball Retainer
3001	Main Frame
A-3004	Elbow Connector
3005	L.H. Bearing Grease Tube (Approx. 22" long)
3007	R.H. Bearing Grease Tube (Approx. 17" long)
3008	Leg Bearing Grease Tube (Approx. 19" long)
3201	Main Shaft
3206	Puller Cam
3401	Puller Slide Support
3402	Puller Slide Rod
3403	Puller Slide
3404	Ware Plate
3406	Positive Return Tension Screw
3407	Spring and Positive Return Housing
3408	Plunger
3409	Spring
3410	Spring Guide Pin
3412	Slide Block
3413	Grease Cup Bracket
3414-A	Bearing Bracket
3415	Puller Slide Lever
3416	Puller Slide Lever Shaft
3418	Cam Roll Stud
3419	Cam Roll
3421	Stroke Bracket
3422	Adjusting Screw
3423	Adjusting Nut
3424	Bearing—(7/8"-10 x 7/8" OD)
3425	Bearing—(7/8"-10 x 15/16" OD)
3426	Slide Guard—Front
3427	Slide Guard—Rear
3428	Return Rod—Replace with 3428A
A-3440	Puller Wedge Assembled
3440	Puller Wedge

## MATERIAL PULLER MECHANISM

Part No.	Description
3442	Stud
A-3443	Handle with Ferrule
A-3445	Slug Puller Release Plate Assembled
3448	Puller Wedge Shim—2—Point
A-3450	Slug Puller Release Plate Assembly 6-18 pt.
3451	Puller Wedge Shim—4-Point
3453	Puller Wedge Shim—6-point
3455	Puller Wedge Shim—12-point
3902	Style 45, $\frac{3}{8}$ -16 x $2\frac{1}{4}$ " long Socket Head Cap Screw
3909	No. 10-32 x $\frac{1}{2}$ " Socket Head Cap Screw
3916	10-32 x $\frac{3}{8}$ " Socket Flat Head Cap Screw
3917	Style 44, No. 5-44 x $\frac{3}{16}$ " Socket Set Screw
3920	Adjusting Screw Retainer
3922	Style 45, $\frac{1}{4}$ -20 x $1\frac{1}{4}$ " long Hexagon Socket Cap Screw
3946	Style 56, $\frac{1}{2}$ " diameter x $1\frac{1}{8}$ " Dowel
3947	Style 56, $\frac{3}{32}$ x $1\frac{5}{16}$ " Dowel
3961	Wave Washer ( $1\frac{1}{16}$ " OD x $\frac{1}{2}$ " ID x .010" thick)
3981	Oiler
3986	No. 13 ( $\frac{3}{32}$ " x 1" long Escutcheon Pin
3990	$\frac{1}{4}$ " Dia. Steel Bearing Ball
6049	Style 44, $\frac{1}{4}$ -20 x $\frac{5}{16}$ " long Hexagon Socket Cup Point Set Screw
6154	Style 45, $\frac{1}{4}$ -20 x $\frac{3}{4}$ " long Hexagon Socket Cap Screw

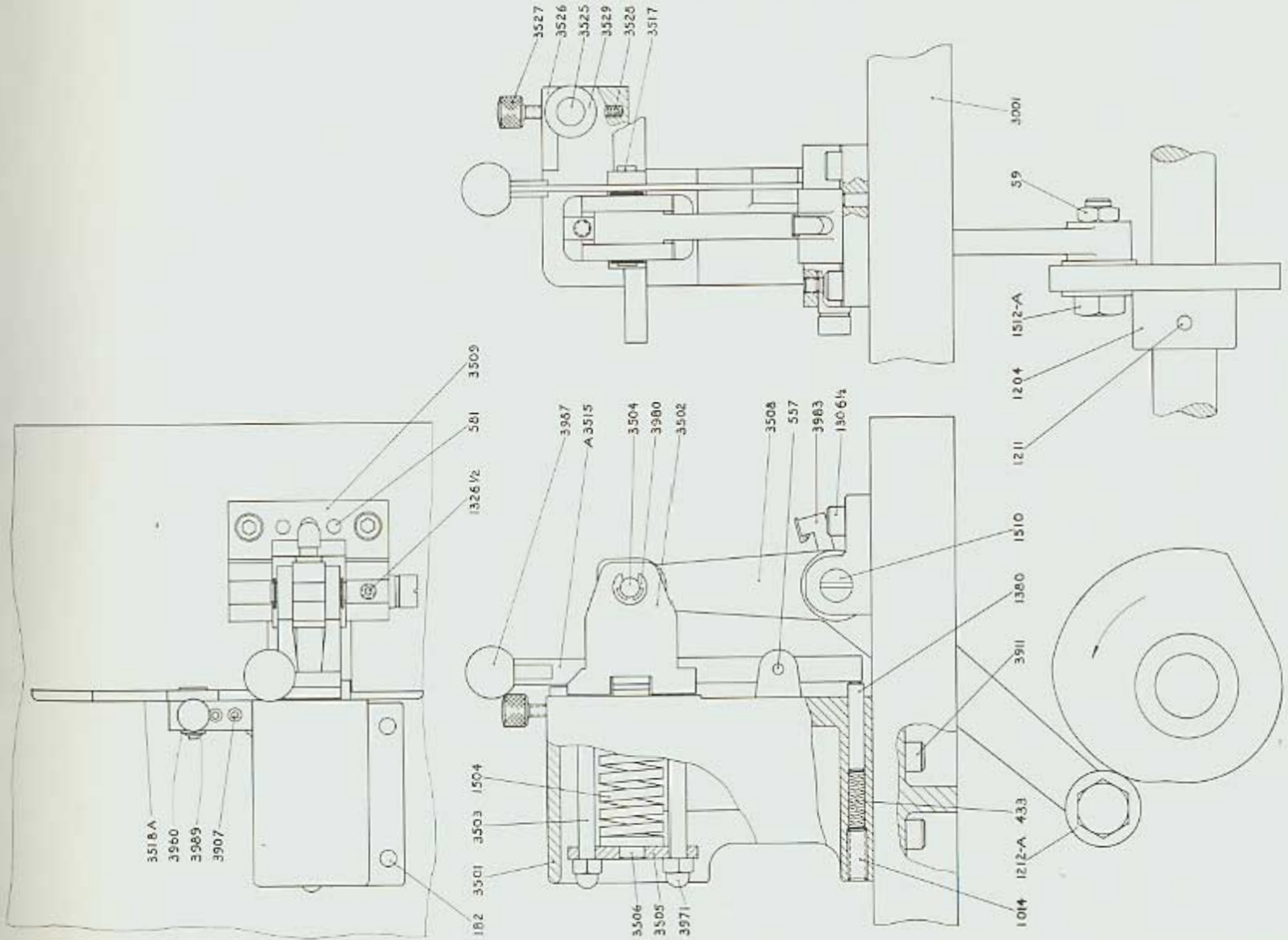

MATERIAL CLAMPING MECHANISM

## MATERIAL CLAMPING MECHANISM

Part No.	Description
59	Style 101, 1/2"-13 Thick Hexagon Nut x 5/16" Thick
182	Style 56, 5/16" Dowel Pin x 1 1/4" long
433	Clutch Release Yoke Spring
557	Style 56, 3/16" Dowel Pin x 3/4" long
581	Style 56, 1/4" Dowel Pin x 7/8" long
1014	Style 44, 3/8-16 x 1/2" long Hexagon Socket Cup Point Set Screw
1204	Material Clamp Cam
1211	Style 55, No. 5 Taper Pin x 2" long
1212A	1 1/2" Dia. x 7/8" long Cam Roll
1306 1/2	Style 45, 3/8-16 x 1" long Hexagon Socket Cap Screw
1326 1/2	Style 44, 5/16-18 x 5/16" Hexagon Socket Set Screw
1380	Style 56, 5/16" Dowel Pin x 2 1/8" long
1504	Material Clamp Spring
1510	Material Clamp Lever Fulcrum Pin
1512A	Material Clamp Cam Roll Stud
3001	Main Frame
3501	Material Clamp Bracket
3502	Material Clamp
3503	Clamp Stud
3504	Special Pin
3505	Material Clamp Spring Plate
3506	Plug
3508	Clamp Lever
3509	Clamp Lever Bracket
A-3515	Clamp Lever Assembly
3517	Stud
3518-A	Clamp Block
3525	Stud
3526	Plate
3527	Adjusting Screw
3528	Spring
3529	Guide Roll
3907	Style 45, No. 8-32 x 3/8" Socket Head Cap Screw
3911	Style 45, 3/8-16 x 1 1/4" Socket Head Cap Screw
3960	No. 10 Standard Flat Steel Washer
3971	Style 104, 5/16-18 Steel Hexagon Cap Nut
3980	Snap Ring
3983	Oiler—1/4" Elbow
3987	1" Diameter Ball Knob
3989	C-Ring

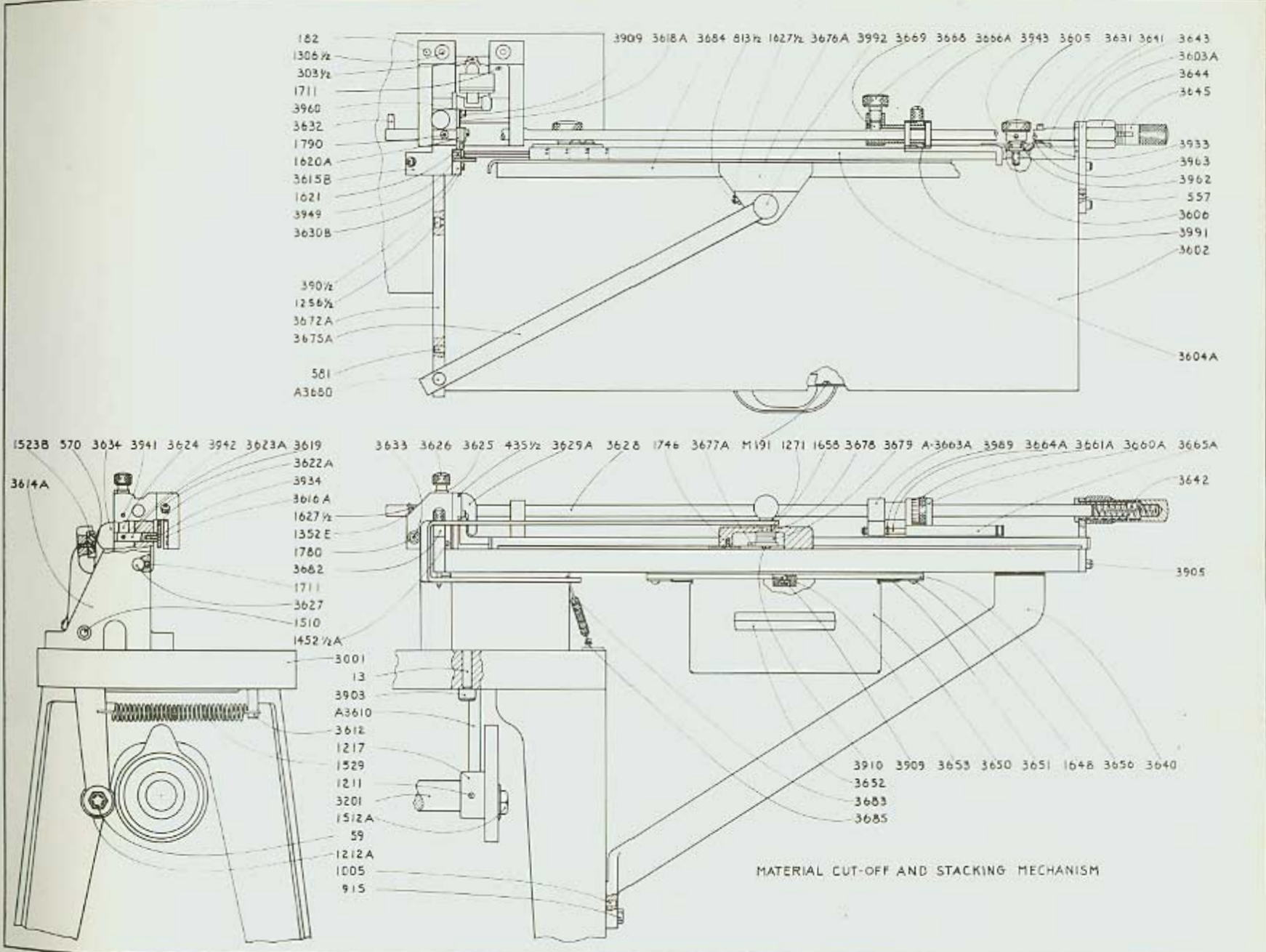

MATERIAL CUT-OFF AND STACKING MECHANISM

## MATERIAL CUT-OFF AND STACKING MECHANISM

Part No.	Description
13	Style 56, $\frac{5}{16}$ " Dowel Pin x $1\frac{1}{8}$ " long
ECM-20	Special Oval Head Screw 8-32 x .625/.610" long
59	Style 101, $\frac{1}{2}$ "-13 Thick Hexagon Nut x $\frac{5}{16}$ " thick
182	Style 56, $\frac{5}{16}$ " Dowel Pin x $1\frac{1}{4}$ " long
M-191	Style 7, 10-24 x $\frac{7}{16}$ " long Round Head Brass Screw
303 $\frac{1}{2}$	Gas Tube Compression Coupling Sleeve (for " tubing)
390 $\frac{1}{2}$	Style 45, 10-32 x $\frac{3}{4}$ " long Hexagon Socket Cap Screw
435 $\frac{1}{2}$	$\frac{1}{8}$ " Diameter x 1" long Roll Pin
557	Style 56, $\frac{3}{16}$ " Dowel Pin x $\frac{3}{4}$ " long
570	8-36 by $\frac{3}{8}$ " Fillister Head Screw
581	Style 56, $\frac{1}{4}$ " Dowel Pin x $\frac{7}{8}$ " long
813 $\frac{1}{2}$	Style 44, 10-32 x $\frac{3}{4}$ " long Cup Point Socket Set Screw
915	Style 3, $\frac{3}{8}$ "-16 Hexagon Head Cap Screw x 1" long
1005	Style 56, $\frac{1}{4}$ " Dowel Pin x $\frac{3}{4}$ " long
1211	Style 55, No. 5 Taper Pin x 2" long
1212-A	$1\frac{1}{2}$ " Dia. x $\frac{7}{8}$ " long Cam Roll
1217	Cut off Cam
1219	Style 7, No. 10-32 Round Head Screw x $\frac{3}{8}$ " long
1256 $\frac{1}{2}$	Style 45, $\frac{5}{16}$ "-18 x $\frac{3}{8}$ " long Socket Head Cap Screw
1271	Style 201, $\frac{17}{64}$ " ID x $\frac{19}{32}$ " OD x $\frac{1}{16}$ " long Steel Washer
1306 $\frac{1}{2}$	Style 45, $\frac{3}{8}$ "-16 x 1" long Hexagon Socket Cap Screws
1352-E	Style 202, #10 x $\frac{3}{32}$ " High x $\frac{3}{64}$ " Wide Lock Washer
1452 $\frac{1}{2}$ A	Special Dowel
1510	Material Clamp Lever Fulcrum Pin
1512-A	Material Clamp Cam Roll Stud
1523-B	Cut off Lever Shoe
1529	Cut off Lever Spring
1610	Stacker Spring
1617	Movable Knife
1620-A	Movable Knife Spring
1621	Movable Knife Spring Pin
1627 $\frac{1}{2}$	Style 102, No. 10-32 Hexagon Nut x $\frac{1}{8}$ " thick
1658	Style 201, $\frac{1}{4}$ " OD x $\frac{25}{64}$ " x $\frac{3}{32}$ " thick Plain Washer
A-1646-B	Stacker Lever Fulcrum Pin Assembly
1648	Style 7, No. 10-32 Round Head Screw x $\frac{1}{2}$ " long
1711	Style 44, $\frac{5}{16}$ "-18 x $\frac{3}{8}$ " long Hexagon Socket Cup Point Set Screw
1746	Style 8, 8-32 x $\frac{1}{4}$ " long Round Head Screw
1780	Style 201, $\frac{9}{32}$ " hole x $\frac{7}{16}$ " OD x $\frac{3}{64}$ " thick plain Washer
1790	Style 4, $\frac{1}{4}$ "-20 Hexagon Socket Cup Point Set Screw x $\frac{1}{4}$ " long
3001	Main Frame
3201	Main Shaft
3602	Material Table
3606	Stud
3603	Bracket
3604	Guide Rail

MATERIAL CUT-OFF AND STACKING MECHANISM

Part No.	Description
A3605	Knob } Sold as A3605 only
A3605	
A-3610	Cut off lever Assembly
3612	Spring Stud
3613	Spring
3614-A	Cutter Head Bracket
3615-A	Cutter Head
3616	Stationary Knife
3617	Guide Dowel
3618	Cover Plate
3619	Adjusting Screw
3620	Guide Pin
3621	Spring
3622	Guide Plate
3623	Guide Plate Rod
3624	Guide Plate Lever
3625	Guide Plate Shoe
3626	Guide Plate Knob
3627	Cutter Head Guide Rod
3628	Cut off Rod
3629	Stripper Blade
3630	Fulcrum Screw
3631	Cut Off Rod Gage Stop
3632	Cut Off Rod Return Pin
3633	Stationary Knife Screw
3640	Material Table Brace
3641	Guide Rail Bracket
3642	Material Gage Adjusting Spring
3643	Material Gage Adjusting Tube
3644	Material Gage Adjusting Nut
3650	Accessories Drawer
3651	Drawer Rail
3652	Drawer Pull
3653	Drawer Stop
3656	Drawer Rail Pad
3660-A	Cut Off Gage Adjustment Frame
3661-A	Cut Off Adjustment Knob
A-3663-A	Cut Off Gage Frame Assembly
3664-A	Cut Off Gage Pin
3665-A	Cut-Off Guide—American Measure
3666-A	Cut-Off Gage Lock Knob
3668	Adjusting Screw
3669	Adjusting Screw Plug
3672	Material Table Bracket
3675	Material Stacker Lever



## MATERIAL CUT-OFF AND STACKING MECHANISM

Part No.	Description
3676	Material Stacker
3677	Style 201, $\frac{3}{8}$ OD x $\frac{5}{32}$ " ID x $\frac{1}{8}$ " thick Special Washer
3678	Material Stacker Pivot Stud
3679	Material Stacker Torsion Spring
3680	Material Stacker Fulcrum Assembly
3682	Material Stacker Fulcrum Collar
3683	Material Stacker Spring
3684	Material Stacker Angle
3685	Material Stacker Spring Stud
3903	Style 45, $\frac{1}{2}$ -13 x $2\frac{1}{4}$ " Socket Head Cap Screw
3905	Style 45, $\frac{1}{4}$ -20 x $\frac{3}{8}$ Socket Head Cap Screw
3909	No. 10-32 x $\frac{1}{2}$ Socket Head Cap Screw
3910	10-32 x $\frac{1}{2}$ " Socket Head Cap Screw
3924	10-32 x $\frac{3}{4}$ " long Socket Head Cap Screw
3930	No. 10-32 x $\frac{1}{2}$ " long Round Head Machine Screw
3933	Style 46, 10-32 x $\frac{3}{8}$ " long Socket Button Head Cap Screw
3934	8-32 x $\frac{3}{8}$ " long Flat Head Socket Screw
3941	Style 56, $\frac{5}{32}$ x 1" long Dowel Pin
3942	Style 56, $\frac{5}{32}$ x $1\frac{1}{32}$ " long Dowel Pin
3943	Style 56, $\frac{5}{32}$ " diameter x $\frac{7}{8}$ Dowel
3944	Style 56, $\frac{1}{4}$ x 1" long Dowel
3949	$\frac{3}{8}$ " Diameter x $\frac{3}{8}$ " long Roll Pin
3962	Wave Washer ( $\frac{3}{8}$ " ID x $\frac{9}{16}$ " OD x .020" thick)
3963	Style 201, $1\frac{3}{64}$ " ID x $\frac{7}{16}$ " OD x $\frac{1}{32}$ " thick Plain Washer
3989	C-Ring
3991	Wave Washer .915/.905 OD x .770/.760 ID x .104/.084 x .035 thick
3992	1" Diameter Ball Knob
6049	Style 44, $\frac{1}{4}$ -20 x $\frac{5}{16}$ " long Hexagon Socket Cup Point Set Screw

NUMERICAL INDEX

Part No.	Shown On Plate No.	Part No.	Shown On Plate No.	Part No.	Shown On Plate No.
13	11	1003-EB	1 & 4	1261	7
24	9	1005	1, 4, 8 & 11	1262-A	7
37½	3, 5 & 6	1010-B	8	1262½	7
40	7	1014	10	1263	7
42	4 & 8	1024	8	1264-A	7
59	1, 4, 10 & 11	1108½	9	1265	7
121½	3 & 6	1109-A	8	1266-A	7
A-129	3 & 6	1110-A	8	1267	7
A-130½	6	1112-A	8	1268	7
148	1 & 4	1112½	8	1268½	7
168	8	1113	8	1269	7
182	9, 10 & 11	1113½	1, 4 & 6	1270	7
185	3 & 6	1116	1, 4 & 8	1271	7 & 11
M-191	11	1129	9	1273	7
192-A	7	1133	3, 5, 6 & 8	1274	7
M-210	8	1136	8	1275	7
230	7	1142	8	1276	7
M-238	8	1143	8	1276½	7
282	4	1161	3	1277-B	7
295½	9	A-1179	8	1278-A	7
A-301	8	1184	8	1278½	7
303½	11	A-1194½-B	8	1280	7
A-320-C	5	1198-C	8	1281-C	7
390½	1 & 11	1198½-A	8	1281½	7
A-391	5	1202-B	1 & 4	1282	7
392	11	1203	1 & 4	1282½	7
433	5	1204	10	1306½	10 & 11
435½	11	1205	1 & 4	1311	1 & 4
451	8	1207-A	1 & 4	A-1315-D	1 & 4
557	4, 10 & 11	1208-C	8	1315½	1 & 4
562	8	1208½	8	1316-A	1 & 4
570	11	1209-A	8	1316½	1 & 4
581	10 & 11	1211	1, 4, 10 & 11	1317½	3
584	8	1211½	1 & 4	1317-B	1 & 4
659½-A	9	1212-A	1, 4, 10 & 11	1318-B	1 & 4
681½	9	1215	1 & 4	1318½-A	1 & 4
717	4 & 9	1217	11	A-1319-A	1 & 4
731	8	1219	8	1320	1 & 4
734	5	1231	8 & 9	1320½	1 & 4
741	7	1243	7	1321	1 & 4
744	7	1245	8	1322½	1 & 4
754	9	1249	1	1323	1 & 4
813½	11	1256½	11	1323½-B	1 & 4
915	11	1258-A	7	1324-B	1 & 4
918	1 & 4	A-1259-A	7	1324½-B	1 & 4
A-1002-D	8	1260	7	1326½	8 & 10

NUMERICAL INDEX

Part No.	Shown On Plate No.	Part No.	Shown On Plate No.	Part No.	Shown On Plate No.
1327-B	1 & 4	1780	11	3305	1 & 7
1332	1 & 4	1783	4	3306	1 & 4
1332½-D	7	1790	11	3307	1
1352-E	11	A-1811	5	A-3315	3
1363	1 & 4	1812	5	3315-1	3
1380	1, 4 & 10	1816	5	3315-2	3
1380½-B	1 & 4	1829	5	3320	1
1382	7	1833-A	4	3321	1
1391½-B	1 & 4	1862	6	3322	1
1391½-E	5	1863	3 & 6	3325	1
1394½-A	1 & 4	1882-B	4	3327	1
1395½	1 & 4	1904-A	1 & 4	3328	1
1396½	4	1949	8	3330	1 & 5
1398-F	1 & 4	3001	1, 4, 9, 10 & 11	3331	1
1398½	4	A-3003	8	3332	1
A-1399½-A	1 & 4	A-3004	1, 4 & 9	3333	1
1399½-A	4	3005	1, 4 & 9	A-3334	3
1406	1 & 4	3006-A	1 & 4	3335	1
1413½	3	3007	9	A-3347	3 & 6
1441	9	3008	9	A-3348	3
1446	9	3009	8	A-3350	3
1449½	4	3105	5	3351	3
1452½-A	11	A-3106	5	3353	3
1473½	1	3108	8	3355	3
1493	1 & 4	3109	8	3356	3
1499	5	3201	1, 4, 8, 9 & 11	3357	3
1504	10	3206	9	A-3358-3	3
1510	10 & 11	A-3226	8	A-3358-4	3
1512-A	1, 4, 10 & 11	A-3227	8	A-3359	3
1523-B	11	3227	3, 6 & 7	A-3360	3
1529	11	A-3228	8	A-3361	3
1612	8	3229	8	3364	3
1614½	1 & 4	3230	8	3365	1
1620-A	11	3231	8	3366	1
1621	11	3232	8	3367	1 & 4
1627½	11	3233	8	3368	1 & 4
A-1641	8	3234	8	3369	1 & 4
1642-A	8	3236	8	A-3392	3
1646½	3 & 5	3237	8	3396	1 & 4
1648	1, 4, 5, 7 & 11	3238	8	3401	9
1649-B	8	3239	8	3402	9
1657½	1 & 4	3240	8	3403	9
1658	11	A-3261	7	3404	9
1711	11	3265	7	3406	9
1730	1 & 4	3283	7	3407	9
1746	11	3302	1	3408	9

NUMERICAL INDEX

Part No.	Shown On Plate No.	Part No.	Shown On Plate No.	Part No.	Shown On Plate No.
3409	9	3606	11	3684	11
3410	9	A-3610	11	3685	11
3412	9	3612	11	3801	5
3413	9	3615-B	11	3802-A	4
3414-A	9	3616-A	11	3803	5
3415	9	3618-A	11	3805-A	4
3416	9	3619	11	3805	7
3418	9	3622-A	11	3810	5 & 6
3419	9	3623-A	11	3811	5 & 6
3421	9	3624	11	3813	5
3422	9	3625	11	A-3814	5
3423	9	3626	11	A-3815	5
3424	9	3627	11	3816	5
3425	9	3628	11	3817	5
3426	9	3629-A	11	3818	5
3427	9	3630-B	11	3819	5
3428	9	3631	11	3820	5
A-3440	9	3632	11	3821	5
3440	9	3633	11	3822	5 & 6
3442	9	3640	11	A-3823	5
A-3443	9	3641	11	3831	4
A-3445	9	3642	11	3832	4
3448	9	3643	11	3834	5
A-3450	9	3644	11	3835	5
3451	9	3650	11	A-3848	6
3453	9	3651	11	A-3858	5 & 6
3455	9	3652	11	3864	5
3501	10	3653	11	3901	8
3502	10	3656	11	3902	1, 4 & 99
3503	10	3660-A	11	3903	11
3504	10	3661-A	11	3904	8
3506	10	A-3663-A	11	3905	11
3508	10	3664-A	11	3907	10
3509	10	3665-A	11	3909	9 & III
A-3515	10	3666-A	11	3910	11
3517	10	3668	11	3911	10
3518-A	10	3669	11	3913	5
3525	10	3672-A	11	3916	9
3526	10	3672	11	3917	9
3527	10	3676-A	11	3920	9
3528	10	3677-A	11	3922	9
3529	10	3678	11	3924	11
3602	11	3679	11	3925	1 & 4
3603-A	11	3680	11	3933	11
3604-A	11	3682	11	3934	11
3605	11	3683	11	3941	11

# NUMERICAL INDEX

Part No.	Shown On Plate No.	Part No.	Shown On Plate No.	Part No.	Shown On Plate No.
3942	11	3962	11	3987	10
3943	11	3963	11	3989	10 & 11
3944	1	3970	5	3990	9
3946	9	3971	10	3991	11
3947	9	3980	10	3992	11
3949	11	3981	9	6049	2 & 9
3960	10 & 11	3983	10	6154	9
3961	9	3986	9	6309	5